

Technical News Bulletin

July, 2016

VertiFlow Assist for AIS machines

Introduction

Additional cooling in the form of “VertiFlow Assist” is now a reality with the introduction of a new Blow mold holder support bracket 210-2076. The new assembly will replace 210-295, and will be the default Blow mold holder supporting mechanism for all AIS machines. The assembly is made up of support bracket 210-2077 and mold shaft assemblies to suit the AIS standard and the AIS+65 section frame assemblies. The additional cooling ‘VertiFlow Assist’ is taken from the section frame supply via cooling wind valves to newly designed mold holder arms; the cooling wind is then conducted to the mold via the insert assembly.

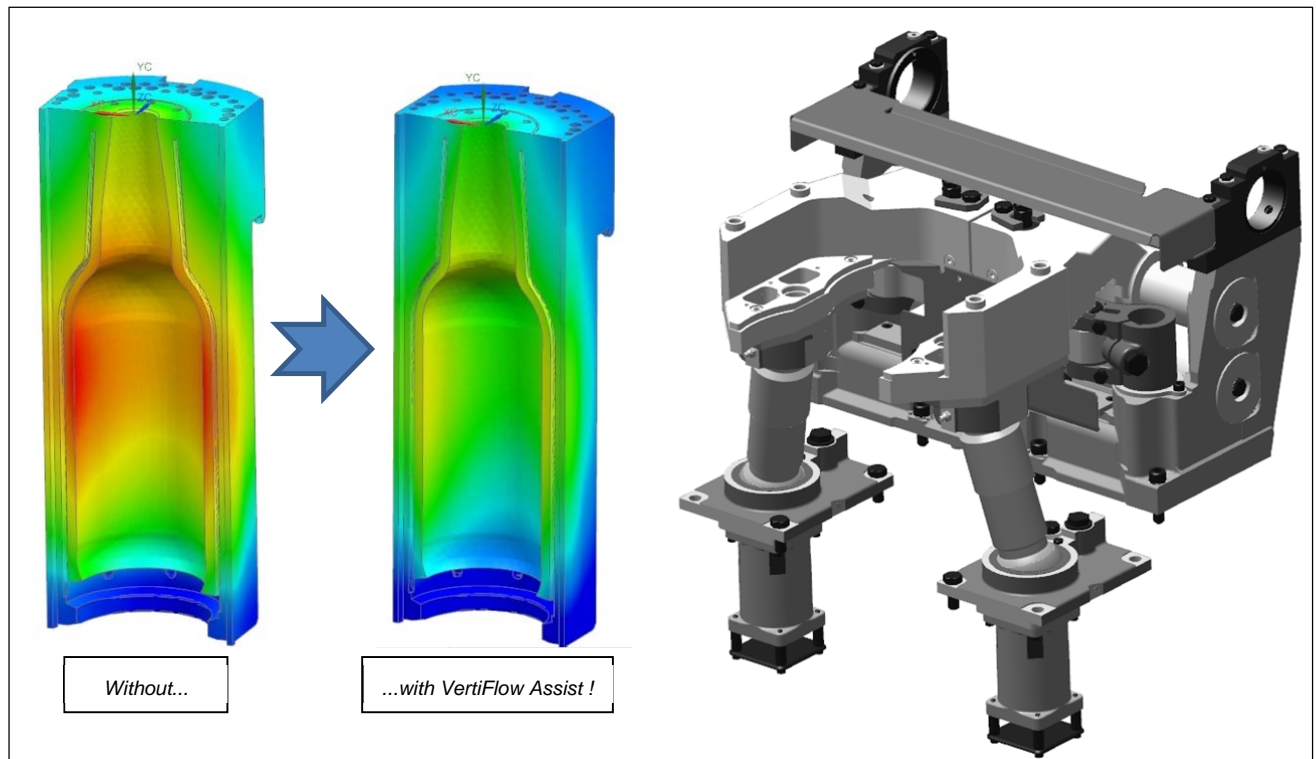

When only using standard VertiFlow through the bottom plate mechanism at higher cavity rates, the Blow mold cooling might reach its limit, so that mold temperatures above 500°C are achieved, usually located in the body/shoulder area of the mold cavity, possibly limiting production speeds and affecting containers' quality. This can become a drawback for NNP&B containers, due to reduced cooling timing duration of the standard VertiFlow: cooling air is available, but for a restricted time, resulting in high Blow mold temperatures, which affects accordingly the containers' quality (leaners...).

Bucher Emhart Glass now introduces the VertiFlow Assist on AIS machines. This additional cooling supplied on the back side of the Blow mold is to be used in conjunction with the standard VertiFlow cooling through the Bottom plate mechanism: VertiFlow Assist is an add on to the standard VertiFlow cooling.

Thanks to VertiFlow Assist, not only we are able to decrease significantly Blow mold temperatures (up to 80°C), but we have the unique capability to influence and balance "vertically" the temperatures on the Blow mold cavity: indeed, standard VertiFlow and VertiFlow Assist can be actuated independently, so that this dual cooling makes it possible for the operator to achieve the right temperature gradient on the Blow mold cavity, to ensure the ideal container quality at higher speeds. Usually, the cooling duration of standard VertiFlow is to be maximized, as this cooling channel is "closer" to the mold cavity, allowing a higher heat removal from glass; the cooling duration of the VertiFlow Assist is defined in a way to achieve the right targeted temperature range, not too hot, and not too cold. By principle, it is possible to keep the VertiFlow Assist cooling channel ON for 360°, allowing a decrease of the temperatures gradient [min-max] in the mold, increasing consequently mold lifetime (less stress in the mold material).

Specification

The system components are listed below: it should be noted that new holders have been designed to ensure that the new bracket is backwards compatible with older insert assemblies 191-9194 for TG operation and 191-9198 for DG operation, thus ensuring that existing molds can be used.

It is also possible to use the majority of existing molds with VertiFlow Assist insert assemblies, as the mold design setups (mold diameter, "H" dimension) stay unchanged between the older insert assemblies and the VertiFlow Assist insert assemblies.

Section Frame

	Mold Holder Supporting	Cooling Valve Assembly
Standard section frame	210-2076-2	210-2028-3
+ 65mm tall ware frame	210-2076-3	210-2028-4

Accessories and variables

The accessories are defined on drawing 210-115: an extract is shown below, for both DG and TG operations, based on the various standard mold design setup assemblies available on the AIS machine:

Mold diameter	"H" dim	"W" dim	"S" dim	Parts references for AIS DG application		
				Without VertiFlow Assist cooling (note1)		With VertiFlow Assist cooling (note2)
				Insert	Insert	Mtg parts
5 3/8" - 136.3	9.5	82.6	68	191-9198-16		
6" - 152.2	9.5	82.6	68	191-9198-20		
6" - 152.2	9.5	127	117.5	191-9198-08	210-2103-08	210-2086-01
6" - 152.2	57.2	130.2	115.6	191-9198-22	210-2103-22	210-2086-02
6" - 152.2	57.2	187.3	172.7	191-9198-09	210-2103-09	210-2086-02
6 5/8" - 168.1	9.5	82.6	68	191-9198-24		
6 5/8" - 168.1	9.5	139.7	125.1	191-9198-25	210-2103-25	210-2086-01
6 5/8" - 168.1	57.2	130.2	115.6	191-9198-23	210-2103-23	210-2086-02
6 5/8" - 168.1	57.2	187.3	172.7	191-9198-26	210-2103-26	210-2086-02

- note1: insert holder kit 210-2078-03 required

- note2: wear mounting plate kit 210-2080-01 required

Mold diameter	"H" dim	"S" dim	"W" dim	Parts references for AIS TG application		
				Without VertiFlow Assist cooling (note1)		With VertiFlow Assist cooling (note2)
				Insert	Insert	Mtg parts
5" - 127	41.3	115.8	127	191-9194-1	210-2099-1	210-2086-3
	15.9	69.7	89	191-9194-2	---	---
	15.9	80	89	---	210-2099-2	210-2086-4
	15.9	115.8	136	191-9194-3	210-2099-3	210-2086-5

- note1: insert holder kit 210-2078-04 required

- note2: wear mounting plate kit 210-2080-01 required

Mold Design considerations and principles: AIS TG

The VertiFlow Assist system is designed to introduce cooling air to the mold with minimal changes. Standard molds can be used without modification, and some of the benefits are achieved, as the air can only escape in the natural gap between mold and insert. The introduction of fins permits a greater air flow volume and increases the surface area exposed to cooling, resulting in a higher mold cooling efficiency.

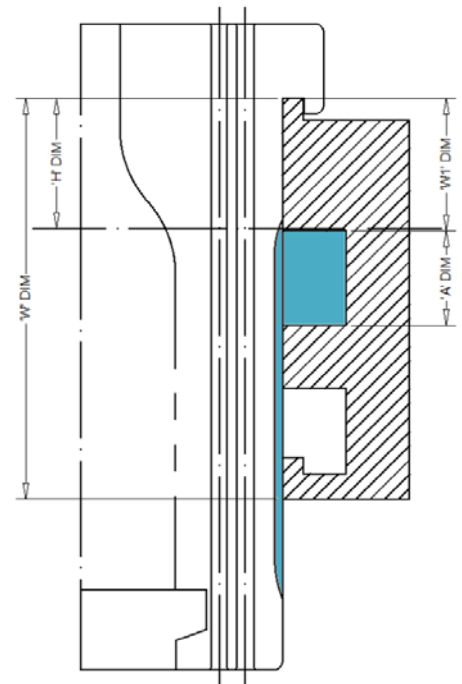
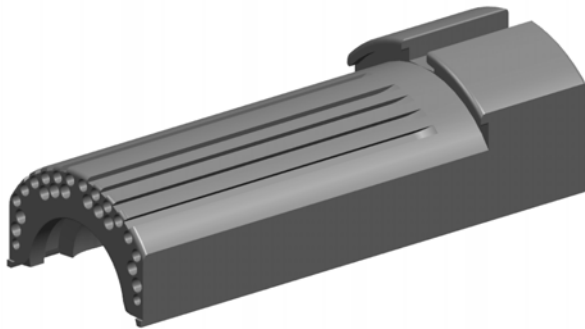

TG 4 1/4" AIS - Mold Holder Inserts							
Part Number	Mold Diameter	'H' DIM	'S' DIM	'W' DIM	'A' DIM	'W1' DIM	
210-2099-01	5"	127	41.3	115.8	117	30	42
210-2099-02	5"	127	15.9	80	89	30	25
210-2099-03	5"	127	15.9	115.8	136	30	35

The total cooling air escape area on the fins needs to be carefully controlled and should not exceed 300mm²: the angular positioning needs to be maintained as shown on the sketch below.

Remark: 210-2099-02 => this insert assembly requires bottom mold lug as shown below.

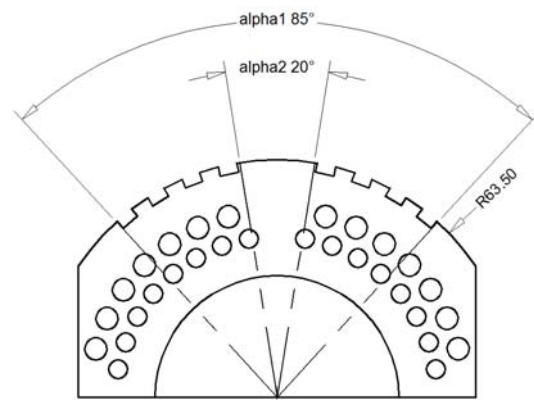
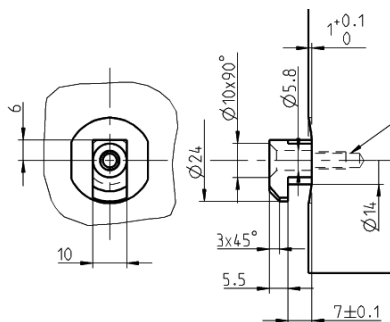

Mold Design considerations and principles: AIS DG

DG 6 1/4" AIS - Mold Holder Inserts								
Part Number	Mold Diameter	'H' DIM	'S' DIM	'W' DIM	'A' DIM	'W1' DIM	Alpha1 °	Alpha2 °
210-2103-08	6"	152.2	9.5	117.5	127	48	28	140
210-2103-22	6"	152.2	57.2	115.6	130.2		28	140
210-2103-09	6"	152.2	57.2	172.7	187.3		55	140
210-2103-25	6 5/8"	168.1	9.5	125.1	139.7		28	110
210-2103-23	6 5/8"	168.1	57.2	115.6	130.2		28	110
210-2103-23	6 5/8"	168.1	57.2	172.7	187.3		55	110

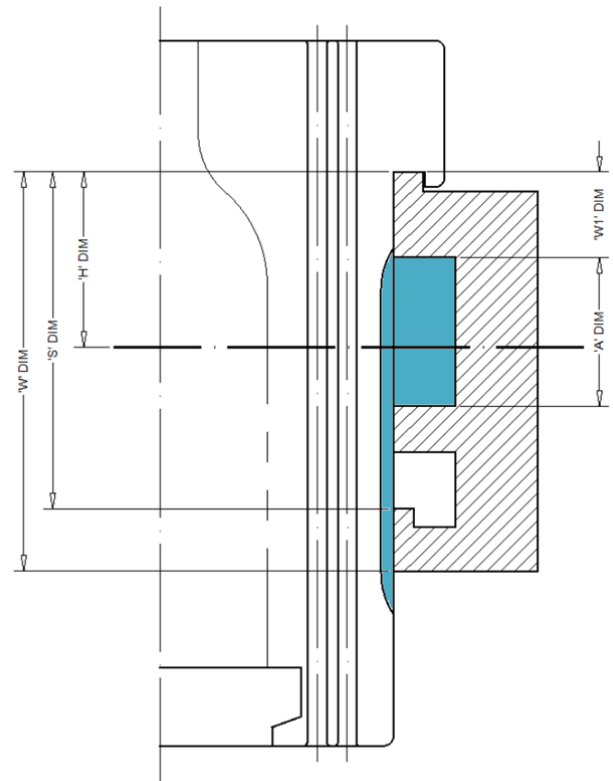
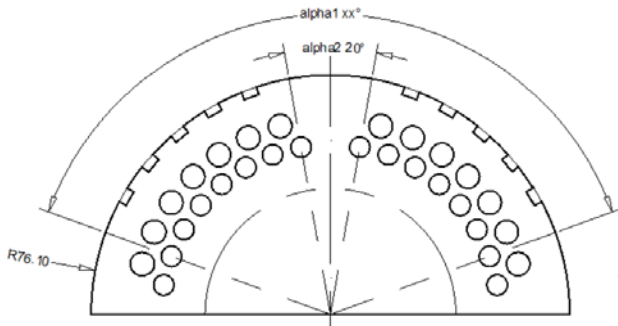

AIS TG: Test case analysis: Theory versus Practice:

To validate the VertiFlow Assist cooling, FEM mold cooling simulations as well as trials under real conditions have been performed in various glass plants. In the example below, the container is a 650ml Beer bottle, 320g, produced in NNP&B on an AIS TG machine.

The thermal models below are all set to the same scale, and show the expected theoretical temperatures for:

- Cast iron Blow mold with standard Vertiflow.
- Bronze Blow mold with standard VertiFlow.
- Cast iron Blow mold combined with both standard VertiFlow and VertiFlow Assist.

The tests were set up with series of molds equipped with thermocouples to record temperatures at the heel panel and shoulder on all cavities (inner, middle, outer). Various design strategies for introducing the additional VertiFlow assist cooling air to the molds were employed, all giving positive results during the field tests. Simple fins on the outside of the molds were chosen as the best interface design between mold and VertiFlow Assist insert: not only the cooling fins provided the best cooling efficiency, but finned molds have the advantage that they can be employed on other machines that are not equipped with the VertiFlow Assist system.

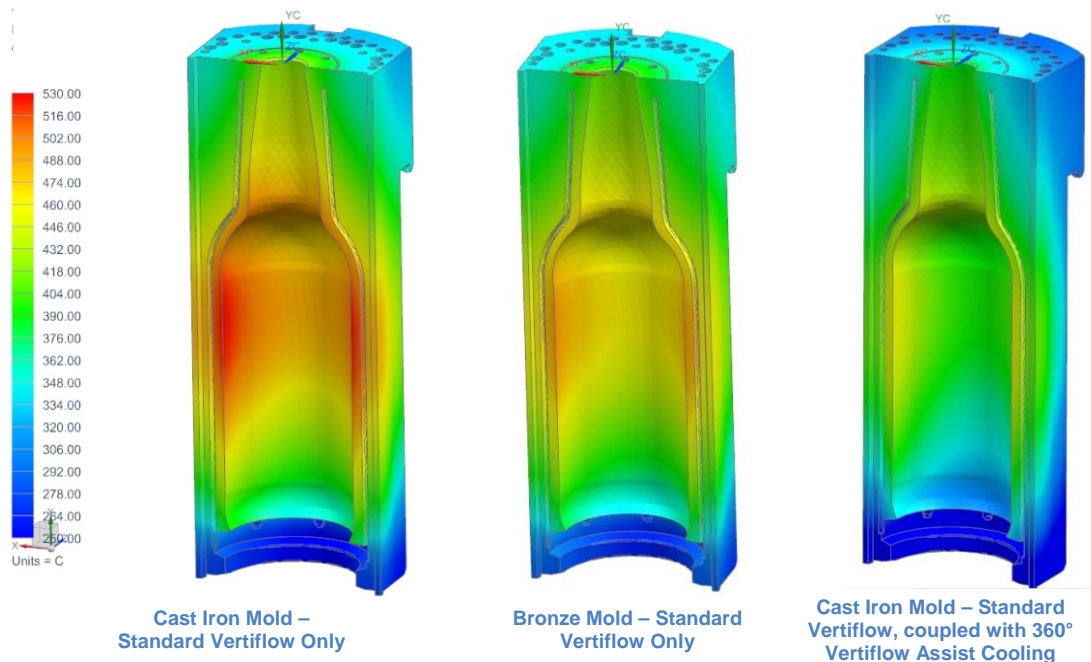

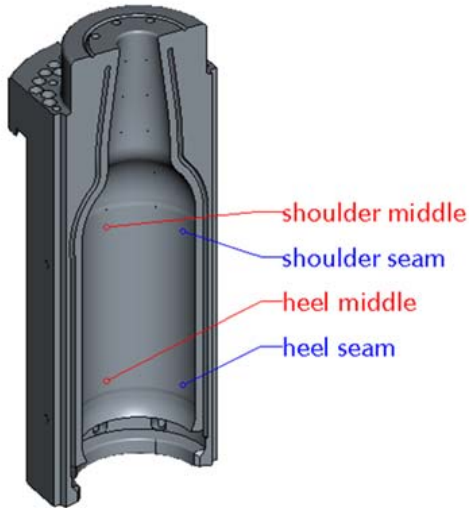

		Description	Cooling Timing Durations		Temperature measurements on Blow mold cavity			
			Standard VertiFlow	VertiFlow Assist	HEEL		SHOULDER	
					At seam	90° from parting line	At seam	90° from parting line
Cast Iron Blow Mold	Test 1	"baseline": Std VF - No VF Assist	Maximized 165°	0°	435	394	520	455
	Test 2	MAX Std VF - Full VF Assist	Maximized 165°	355°	409	360	458	390
				ΔT°C	-26°C	-34°C	-62°C	-65°C
Test 3	Reduced Std VF - Full VF Assist	70°	355°	465	430	470	450	
			ΔT°C	30°C	36°C	-50°C	-5°C	

Another example:
AIS DG - B&B container: FEM mold cooling simulations without and with VertiFlow Assist

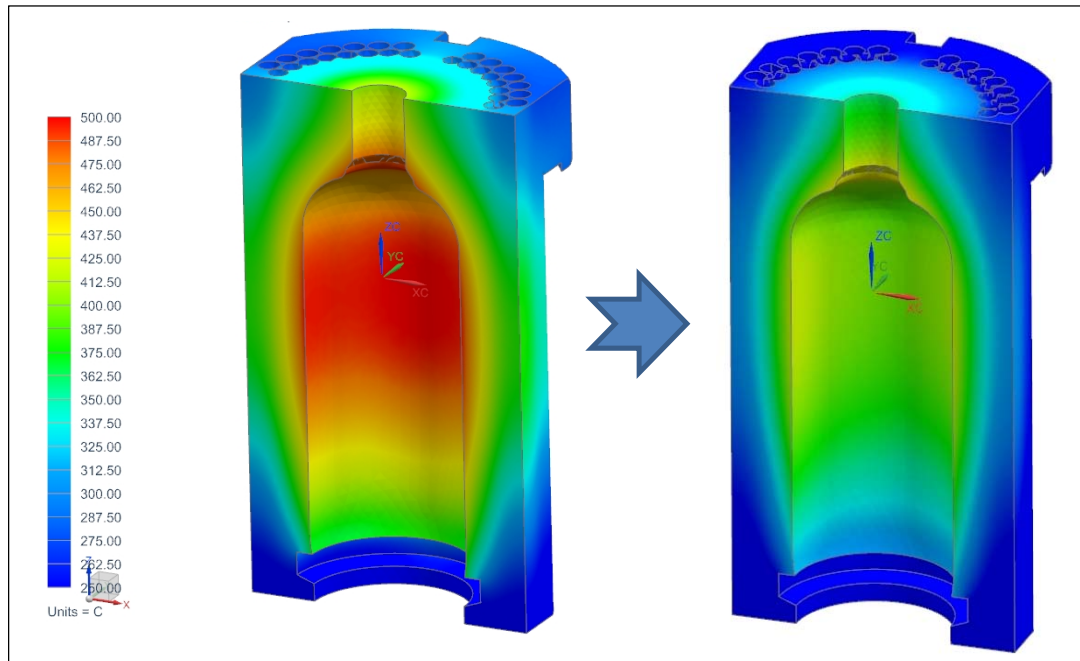

Availability / Application

New supplied AIS machines

The newly introduced Blow mold supporting mechanism 210-2076 is the new standard on the AIS machine, and therefore, all AIS machines supplied from January 2016 can be upgraded to use the VertiFlow Assist cooling system. To that purpose, only the cooling valves as well as the VertiFlow Assist insert assemblies have to be specified.

Conversion of existing machines

The Blow mold supporting bracket 210-2076 can be fitted to all existing AIS machines without modification. However, depending on the manufacturing year and specification of the existing AIS machine, upgrading to VertiFlow Assist requires piping work inside the section, to install the required mold side cooling valves (re-routing of some oil and air piping in the section frame).

Bucher Emhart Glass recommends such an upgrade to be part of a planned shutdown. Contact Bucher Emhart Glass for details.

Remark:

The conversion of an existing AIS machine is supposing that the machine is already “prepared for” being upgraded to VertiFlow Assist, which means that the required air piping for the mold side VertiFlow Assist cooling valves is already connected to the 26 lines valve block.

In case an existing machine does not have this necessary air piping, then the conversion is a challenge, and needs to be carefully investigated and planned.

Features / Benefits

Features	Benefits
Increased cooling capacity	Potential for speed increase / a MUST for NNP&B process
Additional control of vertical temperature profile	Improved Quality of containers
Reduced thermal cycling of mold	Potential increase in mold lifetime
Existing AIS Blow molds can be reused	Low transition costs – Full mold interchangeability