

# Technical News Bulletin



September 2018

## FleXinspect™ T Application Notes

### Section 1 Overview

The FleXinspect T (herein known as the *FleX T*) is a configurable multi-station, servo-indexing rotary inspection system designed to inspect round and non-round glass containers at speeds of up to 400 containers per minute (bpm). The FleX T comes equipped with SCOUT technology software, where everything is based on defect classifications, automatic learned variations and predefined defect limits.



The FleX T can be configured with up to 24 inspection stations, up to nine of which can be equipped with container rotating devices. Actual maximum speed capability and inspection station/rotator configuration varies depending on container size and characteristics, as well as inspections being performed (refer to Section 2, *Ware Range*, and Section 3, *Machine Speed*).

The FleX T is a complete inspection system that includes both the inspection machine and an integrated conveyor system. The machine and its conveyor are designed to be installed at a break in the main production line conveyor (refer to Section 6, *Site Preparation and Installation Requirements*).

The FleX T is capable of performing the following inspections:

#### Standard Inspections

- **Non-contact optical Plug/Ring/Dip/Saddle** 42mm max finish dia – These inspections are performed at a single (rotator enabled) station using three multi-triggering cameras.
- **Check Detection** – Uses modulated lights and receivers with six, pre-set frequencies to perform finish, neck, shoulder, body, heel, and base check detection (with optional base check mounting

hardware). Check detection lights and receivers can be installed at any rotator-enabled station. Standard check detection package includes 8 sensors, and 8 receivers with up to 16 modulated channels (upgradeable to 27 channels).

- **Mold Number Reading** – Heel dot code reader located at any rotator-enabled station (for ease of setup, the front center station is generally preferred).

### Optional Inspections

- **Laser Vision Check Finish Module** – The “LVC” finds cracks in the glass by detecting light scattering. This is done by injecting high intensity, coherent laser light into the glass wall and looking for a disruption in the coherency. Area of inspection is 35mm from top of finish for diameters up to 55mm.
- **Optical Wall Thickness** – The Flex T can be equipped with 4 chromatic thickness measurement inspection systems, which can be mounted at any rotator-enabled station.
- **Sidewall** – Linear scan cameras setup in a rotation station designed to detect sidewall defects (two rotating stations are used, one for upper sidewall and one for lower sidewall).
- **Sidewall Stress** – Linear scan cameras setup in a rotation station designed to detect stress causing defects (Inspection performed in the same stations as the sidewall)
- **Finish Damage Inspection (Wire edge)** – 42mm max finish dia.– Area array vision inspection capable of detecting a range of difficult-to-detect finish defects on the interior or exterior of the finish. (dark field illumination)
- **Sealing Surface** – 120mm max finish dia – Linear scan inspection capable of detecting a range of difficult-to-detect finish defects on the interior or exterior of the finish. (light field illumination)
- **Base** – Linear scan camera setup in a rotation station designed to detect base defects
- **Base Stress** – Linear scan camera setup in a rotation station designed to detect stress causing defects (Inspection performed in the same stations as the base)
- **Base Mold Code Reading** – Vision system capable of reading base dot, peanut or seven-segment numeric mold codes.
- **Mechanical Plug/Ring** – Mechanical go/no-go inspection for min/max plug and ring gauging.
- **Mechanical Dip/Saddle** – Mechanical inspection using conventional FFS head and compressed air to detect effective finishes.
- **2 - point out of round (OOR)** – Linear scan camera inspection measuring the maximum diameter, minimum diameter, and ovality of a glass container in a rotation station. (Flex T can support up to 2 elevations)

- **Dimensional Inspection** – Linear scan camera inspection measuring the lean, diameter and height of a container.
- **Tramp Glass Detection** – Area array inspection to detect foreign objects in the base.
- **Data Matrix Spin Reader** - Camera based data matrix reader. The data matrix code can be located on either the neck or the body of the container.

## **Section 2    Ware Range**

The Flex T is designed to handle both round and non-round containers.

Diameter:    16 up to 170 mm [6.3 in.]

Height\*:     35 to 381 mm [1.38 to 15 in.]

\*Minimum shoulder height for small containers is 21 mm [0.827 in.]; maximum shoulder height for large containers (when the machine is equipped with the large container option) is 260 mm [10.24 in.]

For containers greater than 381 mm up to 450 mm, the tall ware kit (27641A) must be ordered.

**Round containers** include almost all cylindrical round shapes and most tapers within the ware range.

**Non-round containers** are limited to containers that have enough round surface areas in the neck or body to permit the container to be rotated in place. Special tooling is required for handling rotatable non-round containers. Containers also must be delivered to the machine standing upright on a conveyor. Certain shapes with rounded bases, such as ampoules, light bulbs, etc. are excluded.

**Other Considerations:** Some containers (round or non-round) might cause handling problems and should be tested by Emhart Glass. Examples of these containers include:

- Containers with extreme tapers
- Odd round or non-round shapes
- Containers with handles and/or flat or curved label panels
- Small diameter tall, round containers that tend to be top heavy and unstable

**CAUTION:**    **Misshapen and structurally weak containers might break during handling in the Flex T. This might cause unscheduled down time and/or damage to handling components. The installation of a squeeze tester or freak detection device upstream of the Flex T is strongly recommended.**

**Section 3 Machine Speed**

The FleX T is designed to run at a maximum speed of 400 bpm. The actual maximum speed is affected by the container dimensions and shape, as well as the type of starwheel tooling being used: conventional or basket-type. The table below provides a guide to the maximum machine speeds for the various basket-style bottle carrier configurations. Maximum speed also can be affected by plug penetration (only when the FleX T is equipped with optional mechanical plug/ring gauging). The minimum speed of the FleX T is 60 bpm.

**Table 1: Machine Speeds Guide for Basket-style Bottle Carriers**

| # of Pockets | Maximum Bottle Diameter | Rotate Stations | Inspection Stations | Maximum Speed |
|--------------|-------------------------|-----------------|---------------------|---------------|
| 36           | 53mm                    | 9               | 19                  | 400 BPM **    |
| 30           | 66mm                    | 9               | 16                  | 400 BPM **    |
| 24           | 79mm                    | 9               | 13                  | 370 BPM **    |
| 18           | 107mm                   | 7               | 10                  | 320 BPM **    |
| 12           | 152mm                   | 5               | 6                   | 270 BPM **    |
| 9            | 170mm                   | 3               | 3                   | 140 BPM **    |

\*\* Maximum machine speed based on mechanical design, actual running speed is affected by the container shape, size, weight, and inspection options chosen

## Section 4 Tooling

**Tooling Overview:** Standard tooling required for the FleX T consists of:

- 1 or 2 infeed screws (dual infeed screws are recommended for some tall containers).
- 1 bottle carrier assembly. Bottle carriers are available in two styles: conventional-style starwheels (usually upper and lower starwheel assemblies) or the basket-style carrier (Figure 2). Both types of bottle carriers are described below. Bottle carriers are used to transport containers from the infeed screw(s), through the inspection stations, to the outfeed assembly.

If the FleX T is equipped with optional mechanical plug/ring and/or dip/saddle inspections, plug/ring gauges, and FFS heads (dip/saddle inspection) are required.

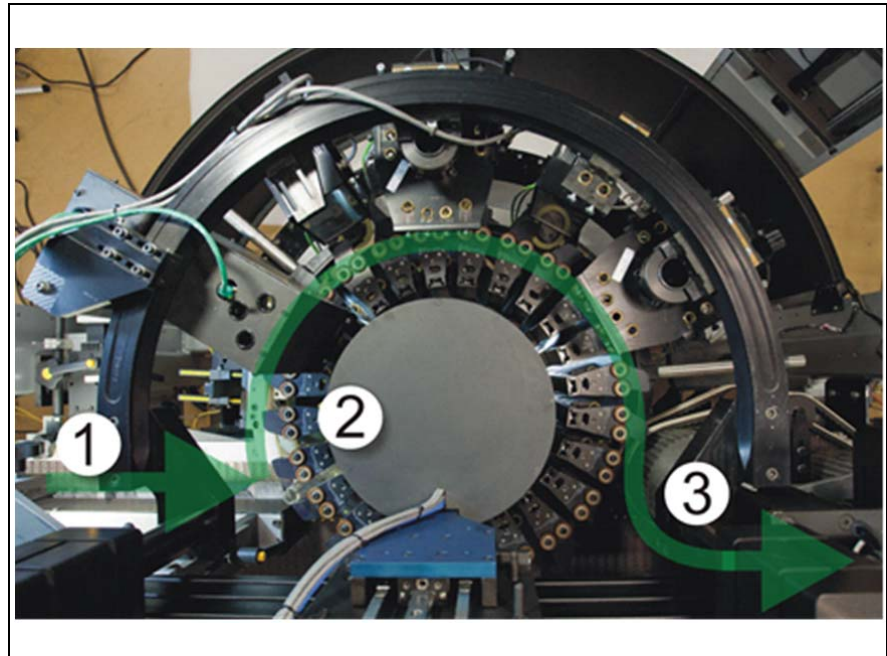

**Figure 2:** Container transport path (basket-style bottle carrier shown)

- |                                                                       |                                                                                   |
|-----------------------------------------------------------------------|-----------------------------------------------------------------------------------|
| 1. Infeed screw transports containers to bottle carrier assembly.     | 3. Outfeed extracts containers from bottle carrier assembly and back to conveyor. |
| 2. Bottle carrier assembly transports containers through inspections. |                                                                                   |

**Infeed Screws:** FleX T infeed screws are bottle diameter and shape -specific.

**Bottle Carriers:** Two types of bottle carriers can be used on the FleX T.

- **Basket style:** This type of bottle carrier includes a 3-section hub with finger assemblies (upper and lower fingers mounted to posts that are configured based on container diameter). The basket-style bottle carrier allows for the use of cameras and light sources installed in front of, and behind, containers at specific inspection stations. Basket-style bottle carriers are available in 9-, 12-, 18-, 24-, 30- and 36-

pocket configurations. The 12- and 24-pocket configurations are the most commonly used and considered standard.

- **Conventional-style:** This starwheel is usually configured as upper and lower starwheels, each comprising three segments that clip onto pins on upper and lower starwheel mounting hubs. NOTE: The conventional starwheel cannot be used for machine configurations that include the sidewall inspection option.
- **Plug/Ring Gauges:** Used only when the FleX T is equipped with optional mechanical plug/ring gauging, plug and ring gauges are specific to the acceptable dimensions of the finish. Plug/ring gauges have Min and Max and length requirements that are container specific. Plug and ring gauges can be purchased from Emhart Glass (if specifications are provided) or blanks of these gauges can be purchased.

**FFS Heads:** Used only when the FleX T is equipped with optional mechanical dip/saddle gauging, FFS heads are specific to the finish diameter of the container and the amount of tolerance allowed for dip and saddle defects.

## **Section 5**    *Inspection Notes*

**Check Detection** – Inspection is limited to predominantly round surfaces on transparent containers. Containers that are opaque, translucent, or have very low light transmittance properties within the spectral range of modulated lights and receivers cannot be inspected. Container surfaces that are not round can present difficulties in inspection. Inspection of these containers might not be possible. Containers that are heavily embossed or lettered may present difficulties in inspection, requiring additional setup time.

- **Laser Vision Check Finish Module** – The “LVC” finds cracks in the glass by detecting light scattering. This is done by injecting high intensity, coherent laser light into the glass wall and looking for a disruption in the coherency. Area of inspection is 35mm from top of finish for diameters up to 55mm.
  - Stones, blisters, and cracks disrupt the light within the glass wall and creates a new light paths within the glass that are then detected by the cameras.
  - Surface features do not affect the coherent properties of the light.
  - Defects are then classified using ADC principles to determine the defect type and limits.

**Mold Number Reading (dot code reader):** The FleX T standard dot code reader is capable of reading dots embossed on the heel of the container. Dots must be within proper specification, with proper clearance from other container markings, to allow proper sensing. The FleX T mold number reader cannot read “peanuts” or numeric codes located on the base of the container. (Base codes, including peanut and numeric, can be read by the optional vision mold number reader.) The dots must be positioned on a round surface on the container, usually in the heel area, although neck and shoulder areas also might be suitable. The reader head must be placed perpendicular to the container at the elevation of the dots. Certain container shapes

might cause the reader head to be positioned at an angle that conflicts with tooling (guide rails) requiring additional setup time. The FleX T Mold Number Reader supports the following code types:

- 9-dot heel code
- 8- and 9-dot Owens heel code
- 10-dot heel code
- 8-dot BSN heel code
- 6-dot Mini Code

Specifications for the engraving of the Emhart and SGCC codes are described in the document, 16049A, *Specifications for Emhart Glass Mold Number Reader*, which can be obtained from an Emhart Glass representative.

**Base Code Vision Mold Number Reader (optional)** – Image acquisition is performed using a super bright LED light source with a high speed area array matrix camera (640 x 480 resolution) positioned above the container. The FleX T Vision Mold Number Reader supports the following base code types:

- MSC alphanumeric
- 10 dot round bottom
- 8 dot peanut
- 7 dot bottom
- Owens 8 dot bottom

**Vision Plug/Ring/Dip** – Vision plug, ring, and dip/saddle inspections are all performed using three multi-trigger cameras and light sources in a single, rotator-enabled station.

Finish Diameter: 10 to 42 mm

- For plug inspection image acquisition is performed using on-axis directional diffuse light and a high resolution camera with telecentric optics mounted above the rotating container. The FleX T vision plug inspection is capable of inspection for min and max “I” only (refer to Figure 3). It is not capable of dual-step plug gauging often required for corkage bottles. Dual-step plug gauging can be performed only with the mechanical plug/ring gauging option.
- For ring inspection, image acquisition is performed using diffuse back light (same light source that is used for dip inspection) and a high resolution camera to measure “E” and “T” dimensions (refer to Figure 3) of the container’s finish as it rotates in the station.
- For dip inspection, image acquisition is performed using directional lighting and a high resolution camera focused on the top and inside of the finish as it rotates in the station.

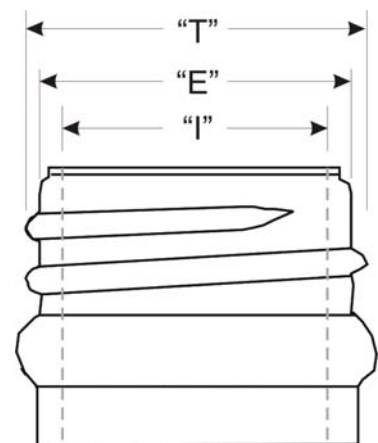

**Figure 3:** Finish dimensions

**Wall Thickness Inspection** – The FleX T can be equipped with an inspection system that uses a chromatic light method to measure glass thickness of containers as they rotate in front of adjustable sensing heads. This inspection also has an ovality inspection used to measure the roundness of a container, as well as a fin detector to detect fins on the mould seams.

- **Chromatic technology sensing system.** This measurement technology uses the color spectrum of light reflected from glass to determine glass thickness of round, as well as some non-round, containers. The chromatic system also uses relatively small sensing heads that can be positioned easily so that almost any area of the container can be inspected as it is rotated in front of the sensing heads. Up to four sensing heads can be installed at any rotator-enabled inspection station.

Testing of the new chromatic system has proven that the accuracy and repeatability of the measurement system exceeds the capability of other measurement systems on the market. A given container will repeat its measured value within  $\pm 1.0\%$  of the median value more than 65% of the time and repeat within  $\pm 3.0\%$  of the median value more than 90% of the time. This repeatability applies to both minimum and maximum thickness measurements.

**Finish Damage Detection** – Inspection is performed using a directional light source and high resolution camera.

Finish Diameter: 10 to 42 mm

**2 Point Out Of Round (OOR)** – This inspection is performed using a linear scan camera to detect out of round containers based on variances in maximum and minimum diameter, as well as maximum acceptable variance from maximum and minimum diameter at a specific position on the container. This inspection can control up to 2 elevations on the container.

**Sidewall Inspection** – The FleX T sidewall inspection is performed using two line scan cameras looking directly through the center axis of the bottle as it rotates, providing a true, 360-degree “unwrapped”, image of the container. The height of the two cameras can be adjusted to provide coverage over the complete height of the bottle. Defects can be seen with no distortion so reject limits can be set using actual defect size. Embossing can be located and inspection performed both within the embossing, as well as around it. The FleX T sidewall inspection is capable of inspecting round, as well as many non-round, containers.

**Sidewall Stress Inspection** – Rotating sidewall stress inspection using high resolution line scan technology with cross polarization. Stress inspection performed with the same cameras as the sidewall inspection.

**Base Inspection** – The base inspection uses high resolution liner scan technology, capturing multiple images of the container as it rotates in the inspection station to inspect for opaque and transparent defects. This provides an unwrapped image of the containers base.

**Base Stress Inspection** – A rotating base stress inspection using high resolution line scan technology with cross polarization. The inspection is performed using the same camera as the base inspection detecting defects such as stones causing stress, viscous knots and no annealing.



**Mechanical Plug/Ring** – Servo position mechanical plug/ring gauge whose position and penetration levels are adjusted in the software. There are separate output measurements for plug and ring. The following defects can be detected: minimum bore, maximum bore, maximum T (over diameter) and minimum E (under diameter). Mechanical plug gauging will affect the overall speed of the machine.

| Maximum Machine Speeds With Mechanical Plug Enabled |          |           |           |           |           |           |
|-----------------------------------------------------|----------|-----------|-----------|-----------|-----------|-----------|
| Plug Penetration                                    | 9 pocket | 12 pocket | 18 pocket | 24 pocket | 30 pocket | 36 pocket |
| 22 mm [0.875 in.]                                   | 140 bpm  | 270 bpm   | 320 bpm   | 320 bpm   | 320 bpm   | 320 bpm   |
| 38 mm [1.5 in.]                                     | 140 bpm  | 270 bpm   | 320 bpm   | 320 bpm   | 320 bpm   | 320 bpm   |
| 54 mm [2.125 in.]                                   | 140 bpm  | 270 bpm   | 280 bpm   | 280 bpm   | 280 bpm   | 280 bpm   |
| 70 mm [2.75 in.]                                    | 140 bpm  | 250 bpm   | 250 bpm   | 250 bpm   | 250 bpm   | 250 bpm   |
| 86 mm [3.375 in.]                                   | 140 bpm  | 220 bpm   | 220 bpm   | 220 bpm   | 220 bpm   | 220 bpm   |
| 102 mm [4.0 in.]                                    | 140 bpm  | 150 bpm   | 150 bpm   | 150 bpm   | 150 bpm   | 150 bpm   |

**Mechanical Dip/Height** – Mechanical inspection performed using a servo positioned FFS (Fluidic Finish Head) whose position and compression levels are adjusted in the software. The following defects can be detected: dipped/unfilled finish, saddled/warped finish, over height and under height.

**Dimensional Inspection** – Dimensional inspection is performed using two linear scan cameras and white LED light columns installed opposite of each other at a 45 degree angle to the conveyor. The following inspections can be performed: Lean, Diameter and Height. The optical enclosure is located outside the outfeed of the machine which requires one of the following conveyor options:

One meter conveyor extension for lean (part # 27080A1)

Two meter conveyor extension for lean and ware selector (part # 27080A)

**Sealing Surface Inspection (wide mouth version)** – Surface inspection using a linear scan camera in a rotary station acquiring multiple images and then unwrapping the image. Used for finishes up to 120 mm.

**Tramp Glass Detection** – This option uses an area array camera and under the dead plate strobed light to acquire four images (microseconds apart) of the base of the container. These four images are compared to each other. Any difference from one image to the other is highlighted by the Tramp Glass tool and is determined to be a foreign object, such as a loose particle of glass (also known as tramp glass).

**Data Matrix Spin Reader** - Camera based data matrix reader. The data matrix code can be located on either the neck or the body of the container. The reader must be located in a rotary equipped station. This inspection is an integral part of the end to end process.

## Section 6 Site Preparation and Installation Requirements

**NOTE:** Machine clearances for the FleX T with remote electronics are shown in Figure 1.

**Area Preparation** The area where the FleX T must include:

- A straight, level area that is free of legs and under-conveyor obstructions (minimum conveyor height is 914 mm [36 in.]). The FleX T cannot be installed on an incline or decline.
- A break in the conveyor approximately 4.2 meters [approximately 13.5 feet].
- A clear height of at least 1569 mm [61.8 in.] above the top of the conveyor.
- A minimum of approximately 3.6 meters [12 feet] upstream and downstream of the FleX T (measured from the infeed and outfeed sides of the machine).

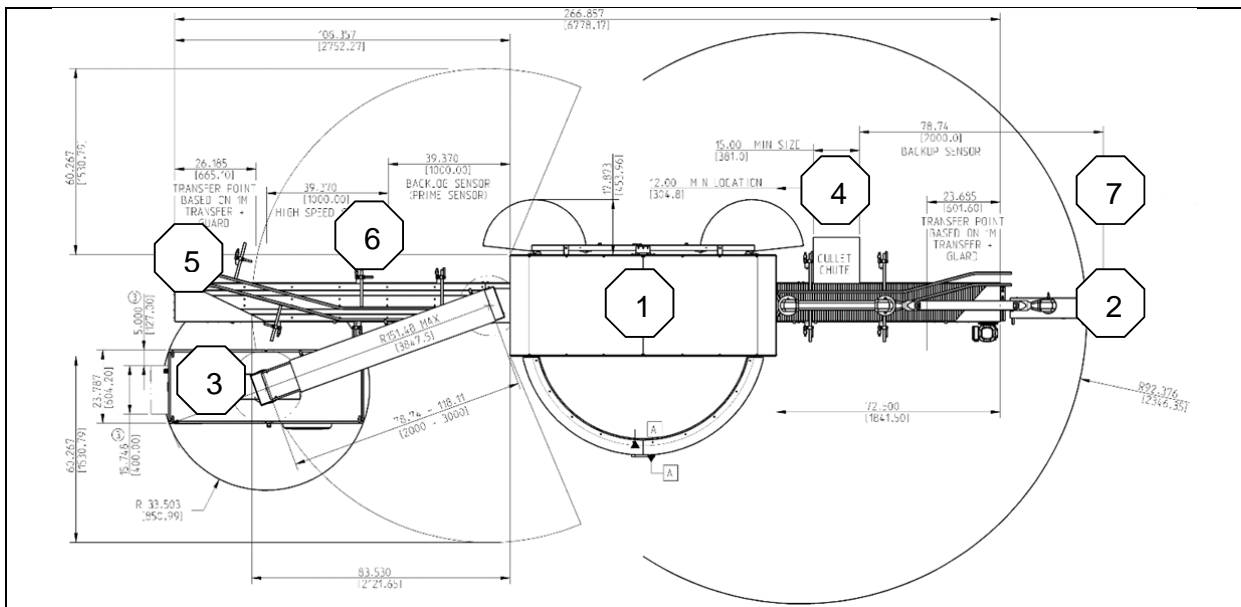

**Figure 1:** FleX T with remote electronics

- |                                     |                                                      |
|-------------------------------------|------------------------------------------------------|
| 1. FleX T machine                   | 5. High speed sensor (minimum distance from machine) |
| 2. User interface                   | 6. Backlog (prime) sensor                            |
| 3. Remote electronics               | 7. Ware back up sensor (recommended position)        |
| 4. Cullet chute (customer supplied) |                                                      |

## Moving the FleX T

The FleX T is a large, heavy machine that requires special handling when moving and installing the machine. Whenever possible, the machine should not be unbolted from its pallet until it is at the installation site.



### **WARNING!**

The crated weight of the machine is approximately 2,500 kg. [5,500 pounds]. The crated weight of the remote cabinet is approximately 670 kg [1,485 pounds].

The machine is front-heavy. If not lifted correctly, the machine will fall forward causing significant damage to the machine and possible serious injury to anyone standing near the front of the machine.

When lifting and moving the machine and the remote electronics cabinet, be sure to follow the installation instructions provided with the machine.

**Conveyor Control System Integration.** The FleX T is designed to interface with most plant conveyor control systems. However, ***Emhart Glass cannot be responsible for the modification or performance of a conveyor control system. Our responsibility is limited to the supply and performance of the FleX T and its integrated conveyor system.*** Any conveyor/machine control issues must be reviewed and resolved during machine specification. Emhart Glass will work with customers and/or their conveyor supplier(s) to meet specific line requirements; however, the customer has the ultimate responsibility for any changes that must be made to the conveyor control to enable interface with the FleX T machine and conveyor.

**Conveyor Control Considerations** When the FleX T is interfaced with a plant conveyor control system, the speed of the FleX T must be set in such a way that speed of the machine and the conveyor retain the same ratio.

There are two ways to achieve this machine-conveyor speed ratio goal:

- Configure the conveyor to follow the FleX T and set the amount of time it takes for the conveyor to accelerate (ramp up) to its new speed to be as short as possible.
- Configure the FleX T to follow the conveyor and set the time that it takes for the conveyor to accelerate to be longer than the time it takes for the machine to accelerate to the new speed.

**NOTE:** *If either of the above two goals is not achieved, ware can accumulate between machines. If the accumulation of ware exceeds the capacity of the conveyor between the machines, containers can fall over or back up into an upstream machine.*

The best way to achieve either of the machine-conveyor speed control goals is to control the speed of the mechanical machine using an analog speed reference signal from the plant line control system to the FleX T.

The following is the formula used to determine the speed of the machine;

Emhart Constant = 4105 = C (This is a value required for the Analog to digital input on the PLC)

B = Bottles Per Minute

D = Bottle diameter of container in MM

V = Voltage in volts

A = Current in Amps

$$V = (B * D) / C$$

$$A = (B * D) / (2 * C)$$

The line control system then must be configured as follows:

1. The line control system sends a speed control signal to the FleX T.
2. Allow adequate time for the FleX T to change its speed and provide a feedback speed reference signal to the conveyor controller telling the controller how fast the FleX T is now running.
3. Set the conveyor controller to follow the speed of the FleX T as closely as possible.

When the above procedure is followed, the FleX T and its conveyor can maintain the correct speed ratio and the conveyor control system can respond to a speed change demand as quickly as possible, thereby reducing ware flow problems upstream or downstream of the FleX T.

#### **Air and Power Requirements**

**NOTE:** *It is the customer's responsibility to provide a stable, clean power supply to the FleX T. Power fluctuations (high or low voltage conditions) can cause the FleX T to shut down and/or stop unexpectedly, as well as damage electronic components in the machine.*

*Power:* 380 to 480 VAC, 3 phase, 25 amps (max. consumption: 37.3 amps at 460 VAC)

*Air:* 3.5 bar [50 psi] nominal (consumption 0.8 to 0.85 m<sup>3</sup>/minute [105.9 cfm].

## Section 7 Operating Environment

**Enclosures:** All electrical/electronic enclosures used in the FleX T should be considered rated for NEMA 12 and IP20.

The FleX T is equipped with a closed-loop air conditioning system designed to maintain the FleX T internal temperature at or below 50°C [122°F]. The temperature is constantly monitored and the user interface will display the following conditions when temperatures inside the electronic cabinet exceed set points.

| Fault Message            | Description                                                                          | Machine State                                                                                                                                                                         |
|--------------------------|--------------------------------------------------------------------------------------|---------------------------------------------------------------------------------------------------------------------------------------------------------------------------------------|
| Over temperature warning | The temperature inside of the electronics cabinet has exceeded the user set warning. | <ul style="list-style-type: none"> <li>Counters reset</li> <li>Machine status icon is yellow.</li> </ul>                                                                              |
| Over temperature fault   | The temperature inside of the electronics cabinet has exceeded 50 C.                 | <ul style="list-style-type: none"> <li>Machine stopped</li> <li>Red stop button is illuminated</li> <li>Counters reset icon flashing.</li> <li>Machine status icon is red.</li> </ul> |
| Air conditioner fault.   | The electronics cabinet air conditioner has stopped.                                 | <p><b>Note:</b> Machine will not restart until the condition that caused the alarm is resolved and cabinet temperature is below 50 C.</p>                                             |

**Operating Temperatures:** The FleX T is controlled by electronic equipment that is designed to operate in the majority of glass plant environments without modification. However, since conditions can vary from one installation to another, the following operating conditions must be observed. Failure to maintain these requirements will affect the applicable warranties covering the Emhart Glass hardware and software associated with the FleX T. If the proper operating conditions are not maintained, the electronic hardware might not function as designed.

1. The internal temperature (with covers closed) must be maintained at or below 50°C [122°F].
2. The maximum allowable temperature inside the machine is 55°C [131°F]. Although control components can operate at this upper temperature, life expectancy of the electronic components will be reduced. The lowest recommended operating temperature is 5°C [41°F]. Maximum relative humidity is 95%, non-condensing.

**CAUTION!** Components within the electronic consoles must be kept clean. The life expectancy of electronic components will be substantially reduced if they are contaminated with plant dirt (swab oil, dust, etc.). The accumulation of these substances on electronic components causes the actual temperature of these components to be much higher than the temperature of air within the control cabinet.

**Container Temperature:** The machine handling equipment is rated for 60°C [140°F] maximum container temperature at machine infeed. Containers hotter than this can cause damage to handling equipment and can cause the internal machine temperature to rise above acceptable limits as outlined above.

### **Section 8    *Conformity Statement***

The FleX T conforms to the provisions of the following European CE directives and standards:

- Directive 73/23/EEC and amendments (Low Voltage Directive)
- Directive 89/336/EEC and amendments (EMC Directive)
- Directive 89/392/EEC and amendments (Machine Safety Directive)
- EN292 Parts 1 and 2
- EN50081-2 Part 2
- EN50082-2 Part 2
- EN60204 Part 1
- CEN TC151 WG13 PrEN13042 Part 6: Specific Safety Requirements for Hollow Glass – Part 6: Multi-Station Multi-Inspection Machines

### **Section 9    *Specifications Required for Order Entry***

The following items are configurable and require specification when ordering:

- Machine hand
- Plant voltage
- Conveyor height
- Tooling - Container specifications and drawings are required
- Options
- Line layout drawings

## **Section 10 Spare Parts**

Spare parts kits are available for the base machine, as well as for the optional inspections. The FleX T is covered by a one-year parts and labor warranty; however, spare parts kits are strongly recommended. If an adequate supply of spare parts is maintained, critical parts, when needed, will be available if they fail or wear out prematurely. An adequate spare parts inventory also helps reduce downtime or extended unsatisfactory machine operation caused by occasional out-of-stock conditions and time required to order and ship required parts. Parts failing within the specified warranty period will be replaced free of charge when returned to Emhart Glass under a Return Authorization number provided by Emhart Glass.

Spare parts have been organized in the following manner.

**Wear Parts Kit PN 12600D1SP** – This kit contains parts to be considered consumables, these are parts that need to be replaced over time. Items like belts, rollers and rotator tires are included in this kit.

**Basic Spares Kit PN 12600DL/R2SP1**– This kit contains the recommended required parts for the base machine.

**Advanced Spares Kit PN 12600DL/R2SP2** - This kit contains both the basic spare parts, as well as parts to cover almost all failure conditions, including major vision system components (computer, optics, and light sources for plug, ring, dip/saddle inspections).

**Basic Spares Kit WTIS PN 12600DSP3** – This kit contains the basic parts needed to maintain the wall thickness inspection.

**Advanced Spares Kit WTIS PN 12600DSP4** – This kit contains both the basic spare parts as well as parts to cover almost all failure conditions for the wall thickness inspection.

## **Section 11 Training**

Setup operation and maintenance training by Emhart Glass personnel is mandatory for optimum machine operation and extended life. A machine-specific service program also is available for the FleX T. Training programs, offered either at Emhart Glass training centers in Clearwater, Florida (USA) or Leipzig, Germany or at your plant, provide plant personnel with hands-on experience in all aspects of machine job change, maintenance, troubleshooting, and operation. We recommend training for all lead maintenance and setup personnel (at least one per shift). This helps facilitate optimum, 24-hour-a-day machine operation and can virtually eliminate costly machine maintenance and service calls.

### ***Section 12 Special Handling Kits***

Special tooling is required for handling rotatable non-round containers. The following kits are available:

**Non Round Handling Kit (Part # 28153AL/R)** Ware handling kit designed for non-round containers including special guide rails.

**Hybrid Stripper Assembly (Part # 11434C)** a special bottle specific stripper that is mounted on the live outfeed to assist in orienting flat bottles or flasks.

**Handled Ware Orienting Kit (27213A)** a separate, optional orienter used in the last rotating station to orient certain non-round containers (such as handled ware) before entering the outfeed.

**Mini Ware Kit (Part # 26921AL/R)** Ware handling kit designed for small ware.

**Tall Ware Kit (Part # 27641A)** Kit designed for ware ranging in height from 381mm to 450 mm.

### ***Section 13 Shipping Specifications***

Shipment of the FleX T consists of three crates;

- Machine, crated weight of approximately 2,495 KG {5,500 pounds}
- Conveyor, crated weight of approximately 961 KG {2,120 pounds}
- Electronics cabinet, crated weight of approximately 673.6 KG {1,485 pounds}



**Revisions**

| Rev. | Date              | Description                                                                                                                                                                                     |
|------|-------------------|-------------------------------------------------------------------------------------------------------------------------------------------------------------------------------------------------|
|      | 3 Dec. 2010       | Initial release                                                                                                                                                                                 |
| A    | 6 Jan. 2010       | Added machine speed chart, container transport illustration; revised tooling descriptions; corrected figure numbers.                                                                            |
| B    | 20 Sept. 2011     | Added "Moving the FleX T" and warning.                                                                                                                                                          |
| C    | 14 Nov. 2012      | Added sidewall stress, base, base stress, 2 point OOR, mechanical plug/ring, and mechanical dip/height, dimensional and wide mouth SSI to inspection notes. Added special handling kit section. |
| D    | 10 July 2013      | Removed 6 pocket and replaced with 9 pocket                                                                                                                                                     |
| E    | 9 July 2014       | Added section 13                                                                                                                                                                                |
| F    | 12 Jan 2015       | Deleted on board info, changed non round kit part number, added tramp glass.                                                                                                                    |
| G    | 27 March 2017     | Changed training centers                                                                                                                                                                        |
| H    | 18 May 2018       | Added laser vision check                                                                                                                                                                        |
| I    | 24 September 2018 | Added Scout and data matrix spin reader.                                                                                                                                                        |