

Technical News Bulletin

Steinhausen, May 2012

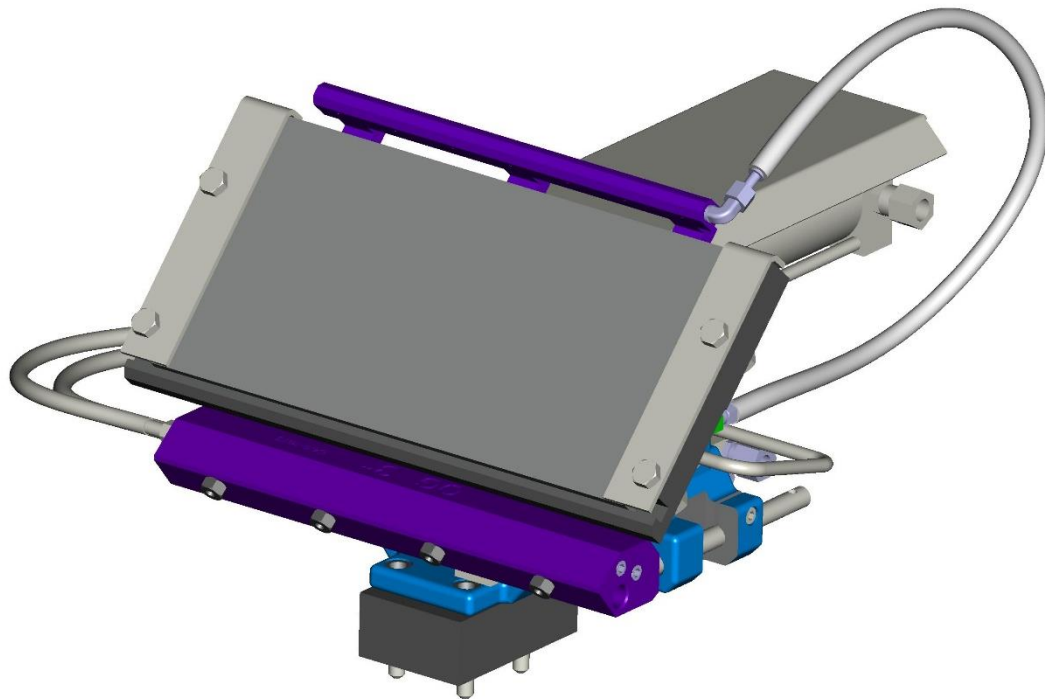

Gob Interceptor 535–200 with Integrated Gob Spray and Interceptor Cooling

- Robust mounting and guide for interceptor plate
- Interceptor plate cooling for trouble-free machine start-up.
- Integrated scoop spray in mounting bracket.

Introduction

The 535-200 Gob Interceptor is a further development to the well-proven 535-142 interceptor.

The Cylinder Mounting Bracket incorporates the mounting for the Spray Head, thus ensuring the spray nozzles are aligned with the gob distributor funnels. Precise intermittent or constant mist spray and close proximity to the gob distributor funnels ensures that lubrication is not wasted.

The assembly is also fitted with a cooling water manifold to give smooth machine start-up and uninterrupted job sampling by ensuring glass does not stick to an overheated carbon plate.

System Description

If possible in a table

Specification

- Fixed angle gob reject
- Carbon interceptor plate
- Cooling manifold for interceptor plate
- Bracket with inbuilt scoop and funnel sprays
- Adjustment for spray bar for different size funnels

Availability / Application

To suit all Emhart Glass gob distributor head combinations

Single Gob	535-200-1
Double Gob 3" Delivery Center	535-200-2
Double Gob 4 3/8" Delivery Center	535-200-3
Double Gob 5" Delivery center	535-200-4
Triple Gob 3" Delivery Center	535-200-5
Triple Gob 4 3/8" Delivery Center	535-200-6
Quad Gob 3" Delivery Center	535-200-7
Quad Gob 1.813" Delivery Center	535-200-8

Installation Requirements

Piping Connections

Operating air piping for the cylinder does not require modification.

The following additional service supplies are required to take advantage of the new features

1. Interceptor Cooling : ¼" RP water connection at inlet valve pressure 2 Bar
2. Gob Spray Lubricant : ¼" RP connection at inlet valve. pressure 2 – 3 bar
3. The gob spray air should use existing connection at the overhead beam air and water unit to the new connection point as shown.

Machine from Jan 2012 are fitted with the 535-200 interceptor unit and details of piping can be found on drawing 200-1699, "Air and Water Piping". Retrofit piping as shown below as per drawing 535-208-5.

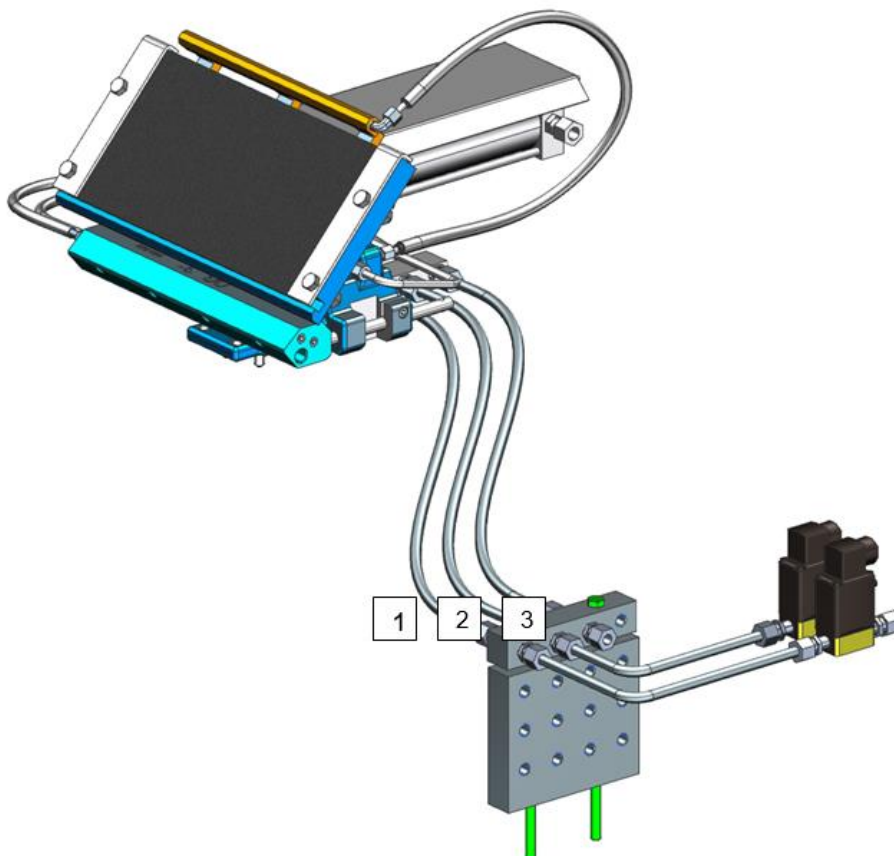

Electrical connections

The interceptor cooling valve should be connected to the cullet water connection of the control system.

For further connection details, please refer to FlexIS schematic drawings 600-10

Features / Benefits

Features	Benefits
Horizontal reject cylinder	Reduced number of moving parts (No linkage)
Double piston rod cylinder	Robust mounting and guide for interceptor plate
Interceptor plate cooling	For trouble-free machine start-up
Integrated scoop spray in mounting bracket	Accurate alignment of spray nozzles to funnels with adjustment for funnel diameters