

CSMulti Container Separator



CSMulti Container Separator

The CSMulti is a container separator designed to space multiple article types with different diameters before entering any inspection machine. The servo-driven CSMulti spaces both round and non-round containers and can be used stand-alone or integrated with FleXinspect machines. This four-belt device can handle speeds up to 600 containers per minute.

Features

- Left or right hand operation
- Spaces containers with diameter differences up to 30mm (1.1")
- Tracks the conveyor for precise container spacing on variable speed lines "encoder based"
- Fits within 1270mm (50") of linear conveyor length / 1000mm (39.3") gap in conveyor

Ware Range

- Height: 40mm - 440mm (1.5" - 17.3")
- Body Diameter: 15mm - 160mm (0.5" - 6.2")

Specifications

- Speed 1m/s (39.3"/s) maximum
- Dimensions L 1270mm (50") x W 540mm (21.2")
- Conveyor chain and sprocket requirements available on request
- IP 50 protection

Power Requirements

- 230VAC single phase 50/60hz Standard - *optional voltages available on request*
- Amps 16

Environmental

- Temperature 5C - Max. 50 °C (41 - 122°F)
- Relative humidity Max. 95% relative humidity

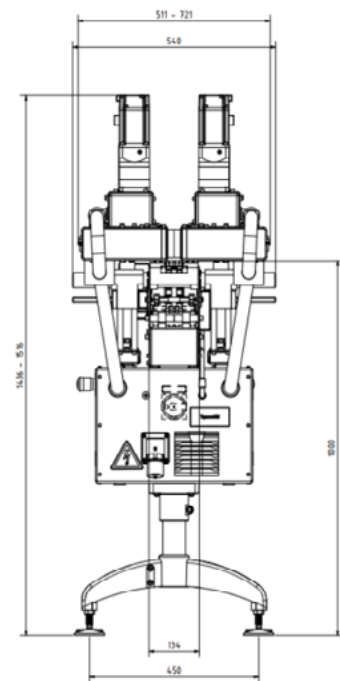
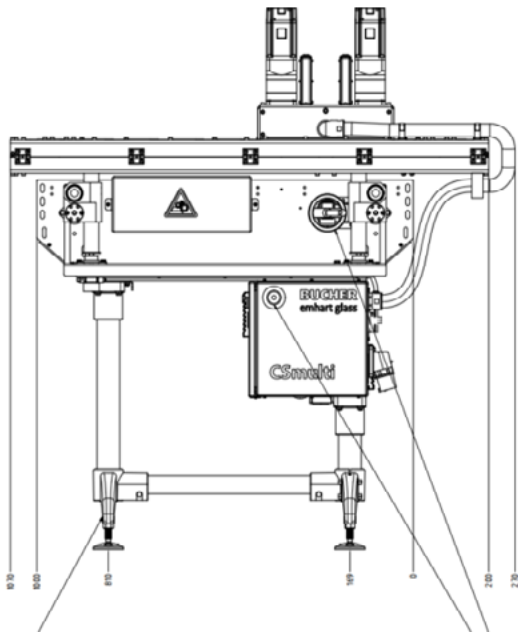
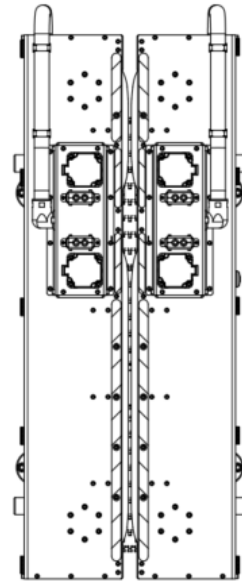
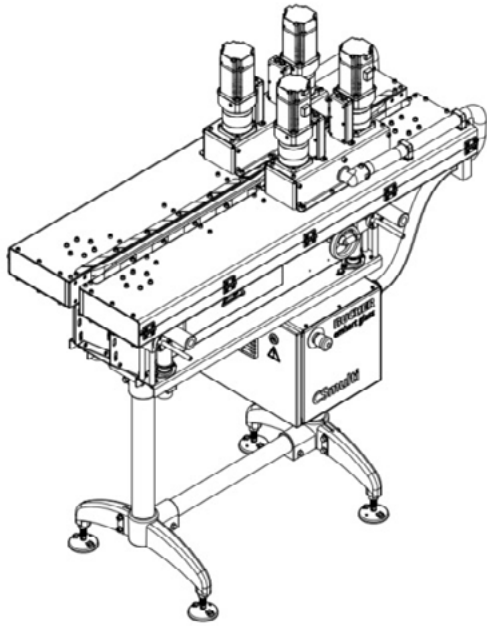

Conveyor shown for reference only

www.bucheremhartglass.com

Bucher Emhart Glass
Hinterbergstrasse 22
CH-6312 Steinhausen

Telephone: +41 41 749 42 00
Fax: +41 41 749 42 71
webmaster@bucheremhartglass.com
www.bucheremhartglass.com