

# Technical News Bulletin

Steinhausen, May 2021

---

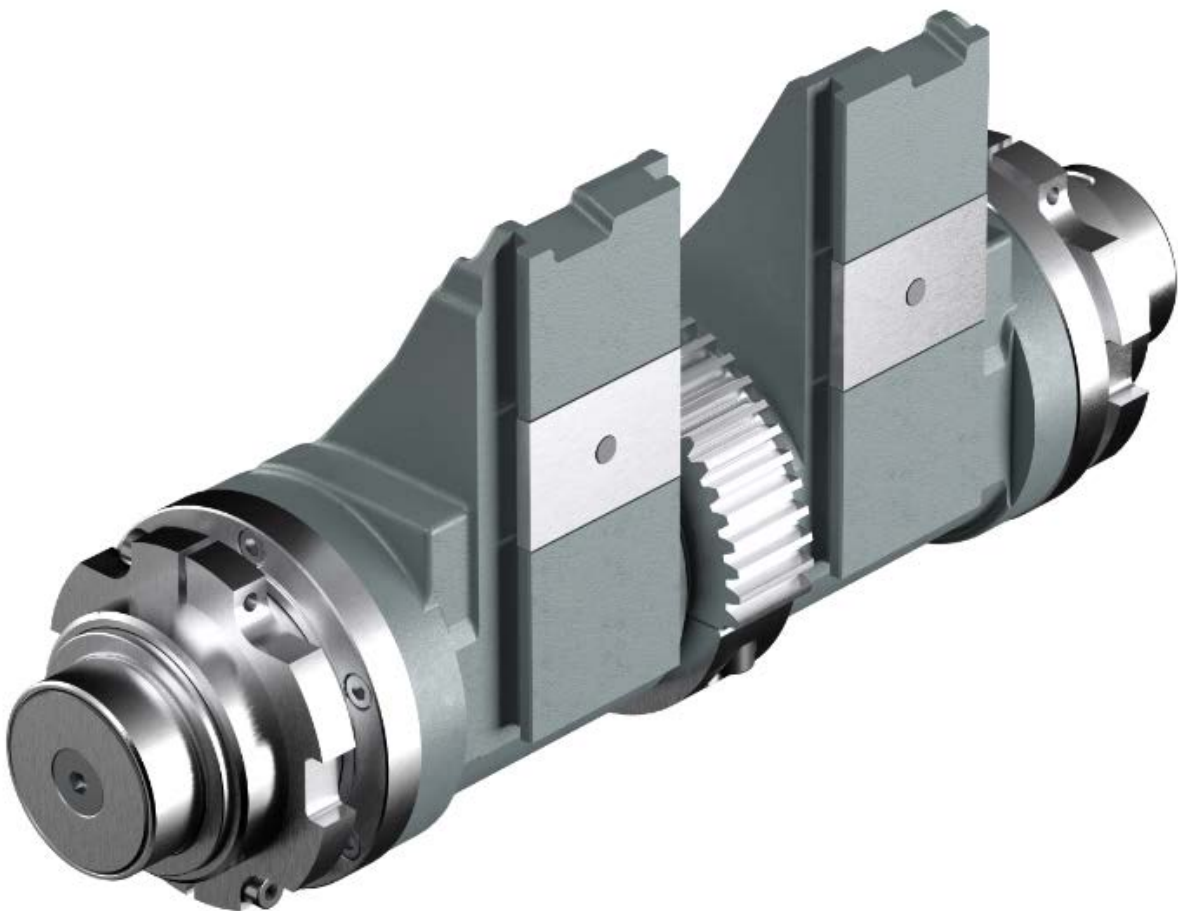

## Roller Bearing Neck Ring Mechanism

- Extended service life
- Internal sealing for higher efficiency
- Improved performances

## Introduction

The Roller Bearing Neckring Mechanism for AIS and IS machines is designed to comply with the demand for increased performances, improved serviceability, and reduced air consumption.

The Roller Bearing Neckring mechanism is available as an option to the conventional Neckring mechanism and is fully interchangeable on every existing IS or AIS machine.

## System Description

The Neckring mechanism with two roller bearings ensures a smooth motion during the parison transfer from blank to blow molds and allows for higher performances by reducing friction and dynamic loads.

Further design improvements have been achieved:

- Improved sealing for reduced leakage
- Neckring mechanism is self-centering between the inner sides of the bracket
- Well balanced and smooth Neckring arm open and close motion
- Enlarged exhaust channels
- Auxiliary Neckring Open on blank side
- Blowside bracket caps are independently machined from the bracket
- Split gear design simplifies the mechanism maintenance

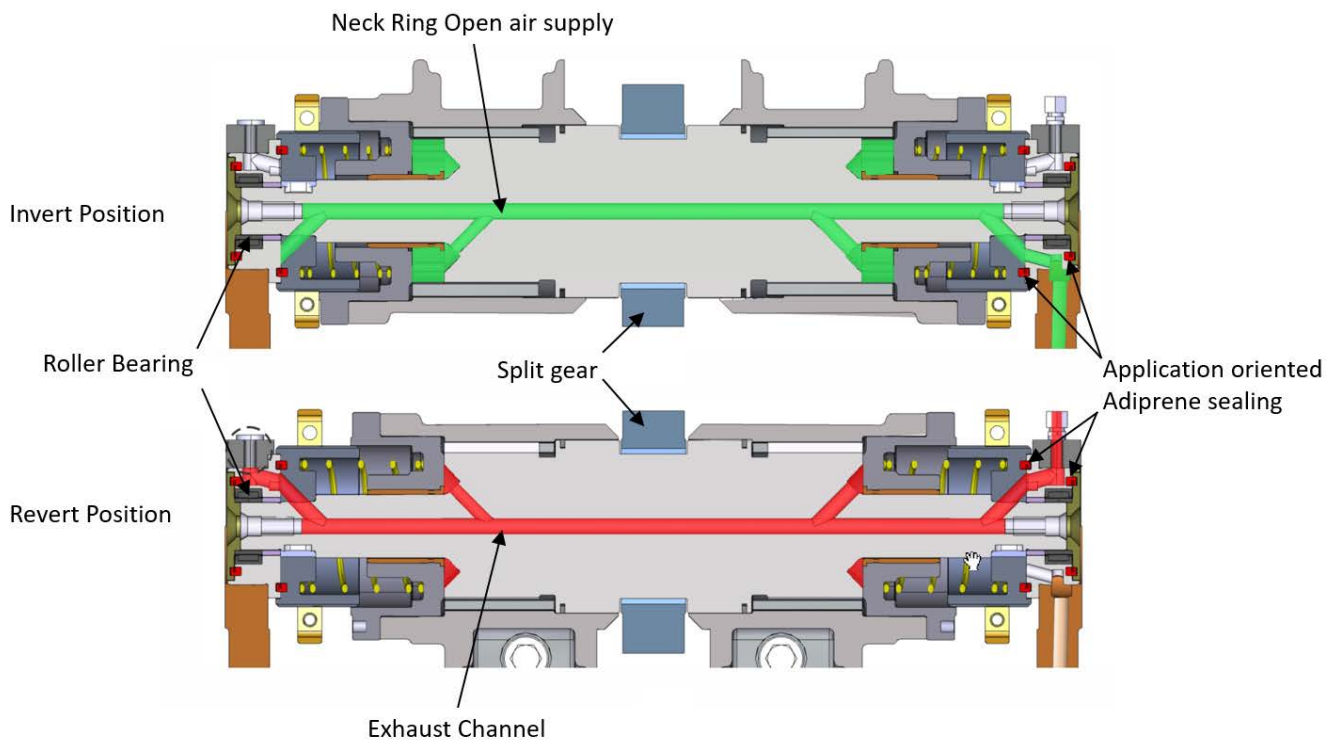

## Specification

The Roller Bearing Neckring mechanism is available with part number **210-2064-1** for IS and AIS machines and for all center distances.

## Installation Requirements

A conversion kit is available for all existing machines:

- Conversion kit 210-2064-4 for IS machines
- Conversion kit 210-2064-5 for AIS machines

Since the Roller Bearing Neckring mechanism 210-2064-1 is sealed to minimize air leakages, the 26 lines valve block must be adapted by replacing the existing needle for Neckring Open adjustment with the fine needle 210-2102-4 to operate at low pressure.

Wear plates installed on the blow mold bracket for the installation of the previous Neckring mechanism are not required anymore and must be removed.

### Features

---

Roller bearing

---

Self-centering mechanism

---

Improved air sealing

---

Split gear

---

Bracket-independent caps

### Benefits

---

Extended service life

---

Smoother dynamics

---

Faster installation/replacement

---

Less leakage

Less air consumption

Balanced Neckring opening

---

Increased performances

---

Increased maintainability

---

Mechanism can be repaired

---

Easier spare parts handling