

Technical News Bulletin

Steinhausen, April 1999

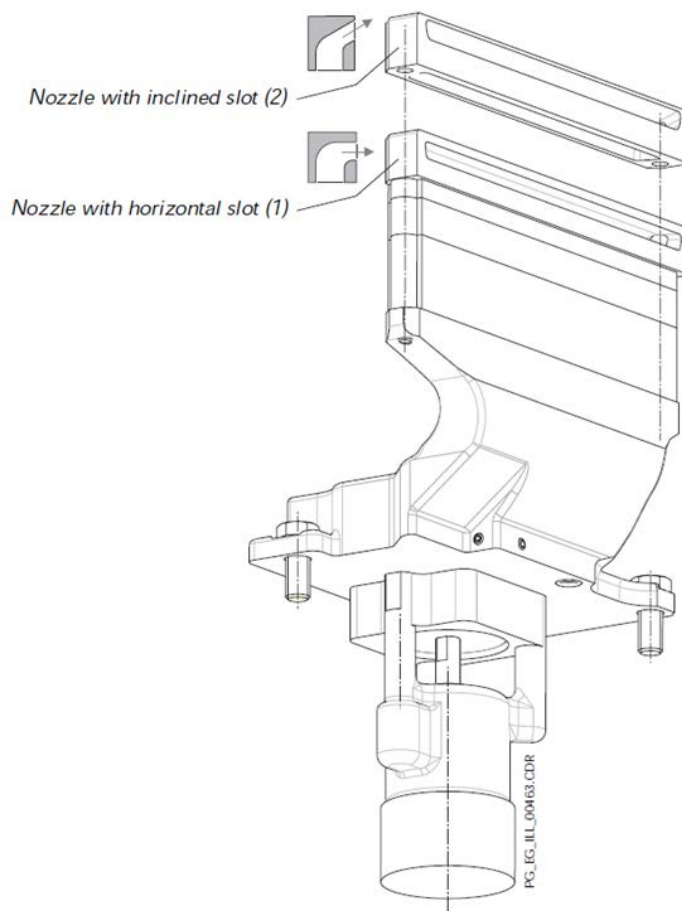

AIS Neck Ring Cooling

- Redesigned for enhanced cooling efficiency and ease of handling.
- Distinguished by its simple and rigid construction the new neck ring cooling system provides 50% more cooling air flow than its predecessor.
- Easier handling at job change.

Introduction

Following the introduction of the blank mold supporting mechanism 210-294 the neck ring cooling was investigated and completely redesigned for enhanced cooling efficiency and ease of handling. Distinguished by its simple and rigid construction the new neck ring cooling system provides 50% more cooling air flow than its predecessor.

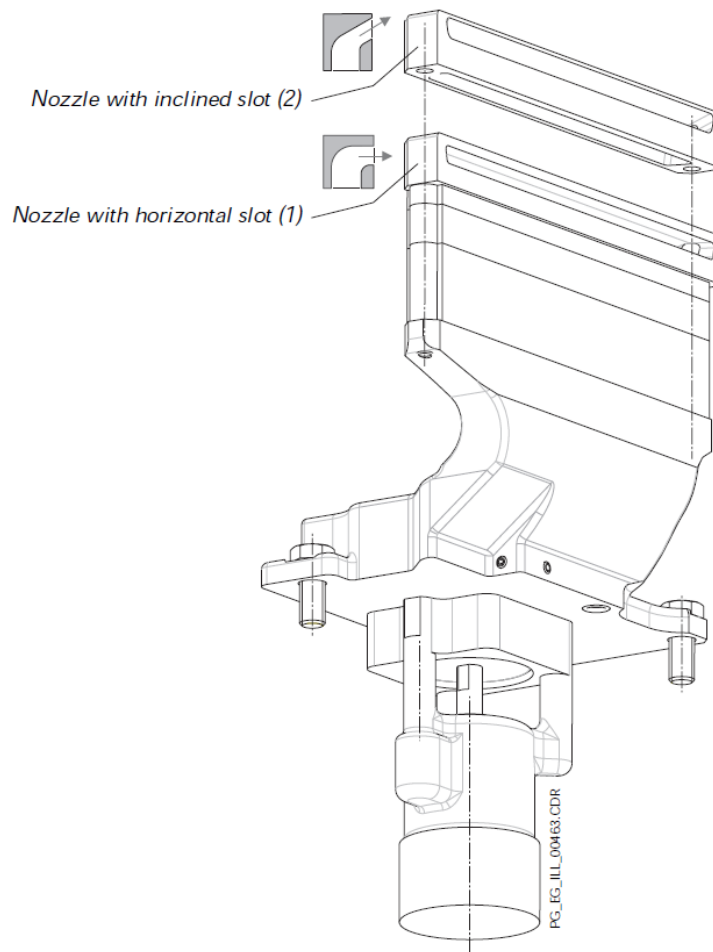

Description

The right and left hand assemblies of the neck ring cooling system basically consist of a base, damper cylinder, nozzles and spacers. The damper cylinder is the one used with earlier neck ring cooling systems. Mounted to the underside of the base, its position relative to the section frame opening has been optimized for improved air intake. The damper cylinder operating air is ported from the original section interface through the base. Two cooling nozzles are available to cover the full application range of DG 61/4 and TG 41/4 operation: One with a horizontal exhaust slot (1) and one with an inclined slot (2). The latter being intended for small ware or for

additional cooling of the blank mold neck ring receivers. The position of the nozzle is determined by different height spacers. Nozzle and spacers are assembled to the base by two screws accessible from the top.

By its design, the new neck ring cooling system works with the blank mold supporting mechanism 210-294 only.

Installation

The installation of the new neck ring cooling system requires no alteration to the section frame and blank mold supporting mechanism. Only the DG 61/4 plunger guide plate must be provided with slight chamfers to clear the nozzle bases.

When replacing existing neck ring cooling assemblies which have the damper cylinders 191-9146-2 installed, these damper cylinders may be reused for the new neck ring cooling system.

Specification

The new neck ring cooling system will be available by May 1999 under the following part numbers:

- 210-402-1 Neck Ring Cooling, RH
- 210-403-1 Neck Ring Cooling, LH

These assemblies comprise the damper cylinder, base, nozzles and spacers including mounting parts for the complete adjustment range. One assembly each is required per section.

With the introduction of the new neck ring cooling system the previous product 210-251 will be no longer manufactured and supplied as complete units. Spare parts will be available until the end of 2001.

Characteristics

- 50% higher cooling efficiency
- Easier handling at job change
- Rigid design
- Well proven damper cylinder