

Technical News Bulletin

Cham, May 2018

UC2 – New FlexIS user interface

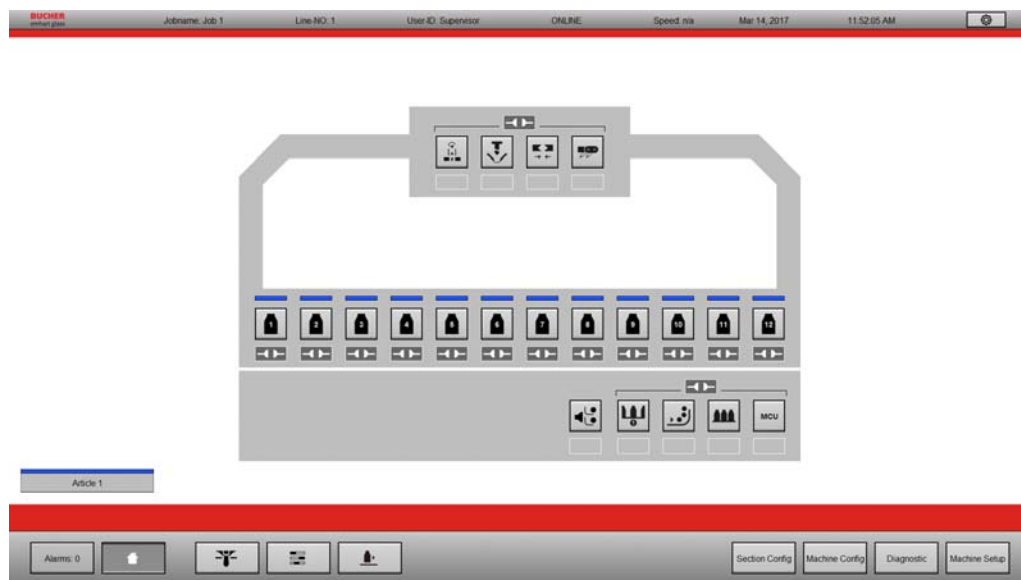

Introduction

Together with the FlexIS 3 Bucher Emhart Glass introduces a new user interface called UC2 (User Console 2). The UC2 sets a new benchmark for the operation of an IS machine. It is a versatile, powerful and user friendly touch screen interface. It uses the state of the art Server-Client architecture, which allows a simultaneous operation on multiple clients. It is also the foundation for any future developments. Especially for the Bucher Emhart Glass End To End developments.

FlexIS Versions

The FlexIS control system consist of three major components:

- User Console (UC)
- Controller
- Servo Drives

FlexIS 3 replaces the UC as well as the realtime controller.

The UC is the interface of the control system for the machine operator. To be able to offer some of the latest developments to existing FlexIS 1 customers, we decided to make the new User Console UC2 available as an upgrade package for FlexIS 1. The FlexIS 1 with UC2 is named FlexIS 2.

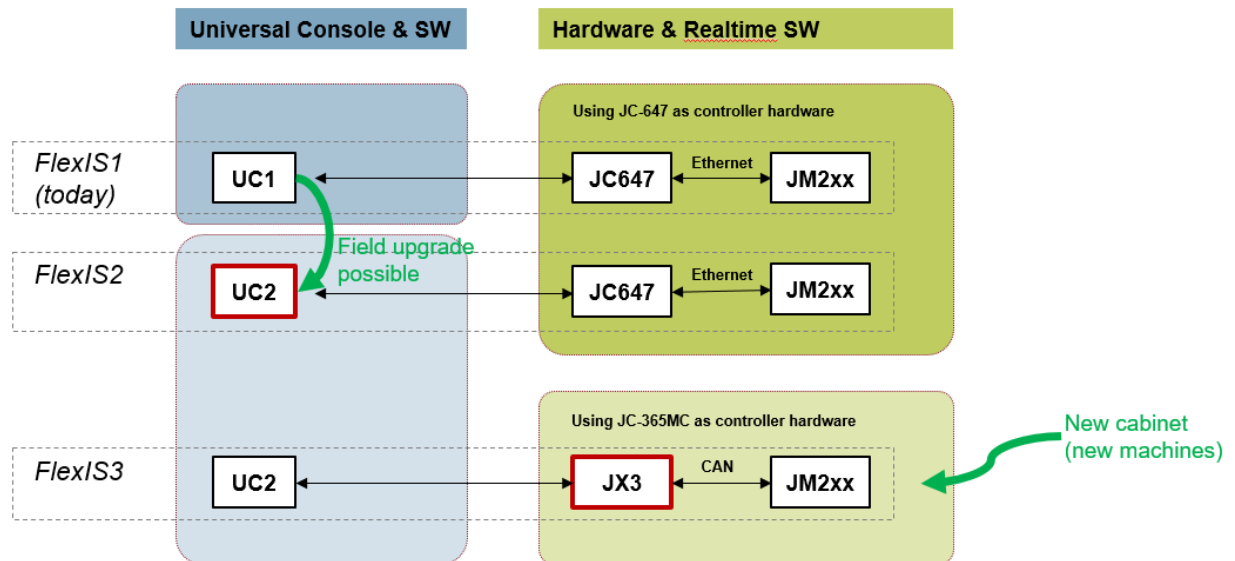

User Interface

Interactive Home Screen

The home screen gives an overview of the status of the machine. It is the main navigation screen and allows direct access to all machine parameter screens.

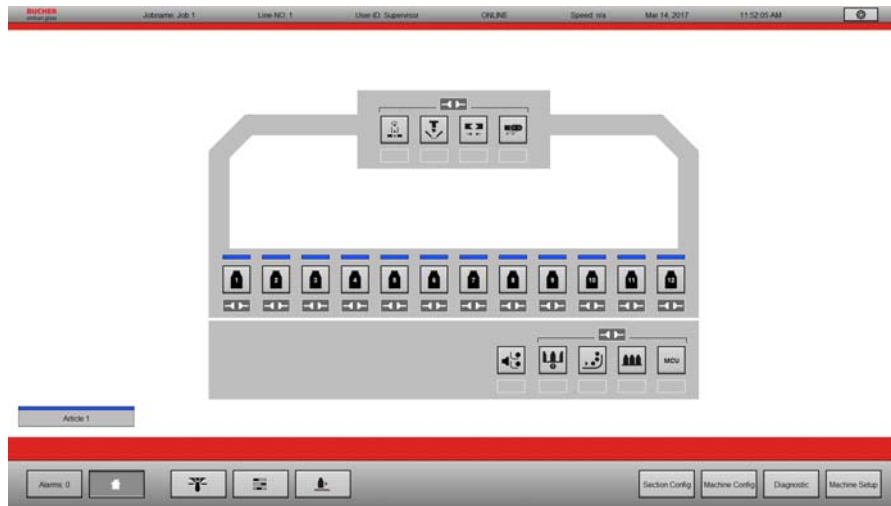

Enhanced Bar Chart

The new bar chart screen is the most noticeable enhancement for the operator. The bar chart screen contains all section settings, which need adjustment during a job run. It allows the adjustment of timing values, FPS valve pressures and servo motion parameters.

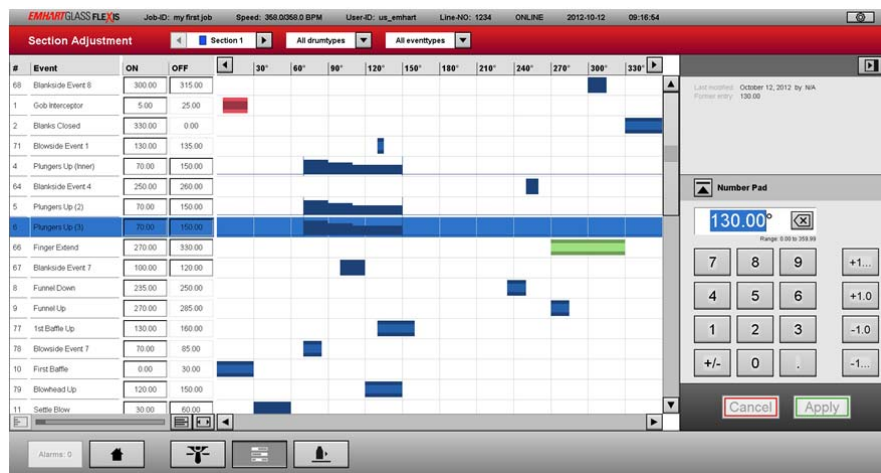

By clicking on the bar you get a detailed view of the FPS pressure settings and its corresponding timing values. All FPS settings can be made in this screen.

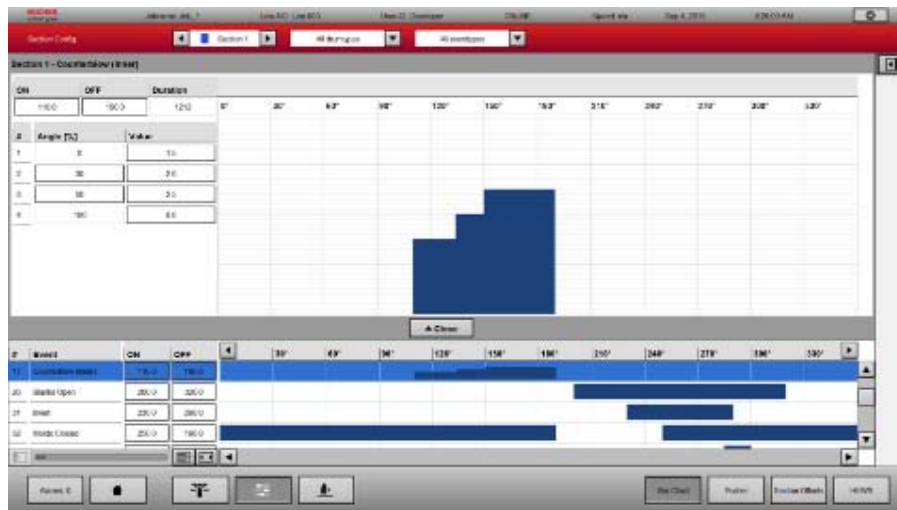

The same is possible for all section servo axis. You can adjust the position, motion duration and ramp settings directly in the bar chart.



Multi Article Operation

A trend in the glass container industry is to run multiple articles on an IS machine at the same time. The UC2 is fully designed for this operation. It allows article settings to be stored and downloaded individually by section. The colors indicate which article is running in which section.

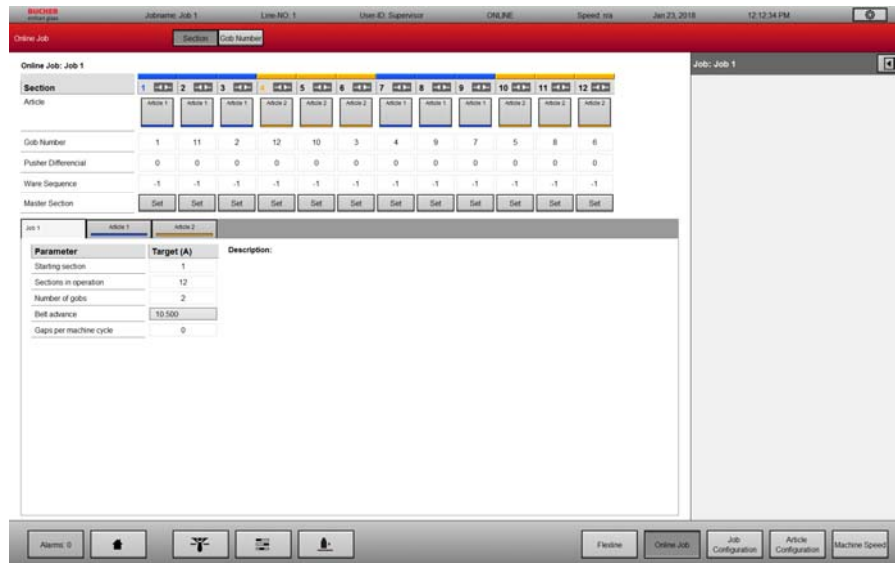

The same color codes and selection possibilities are shown when copying values.

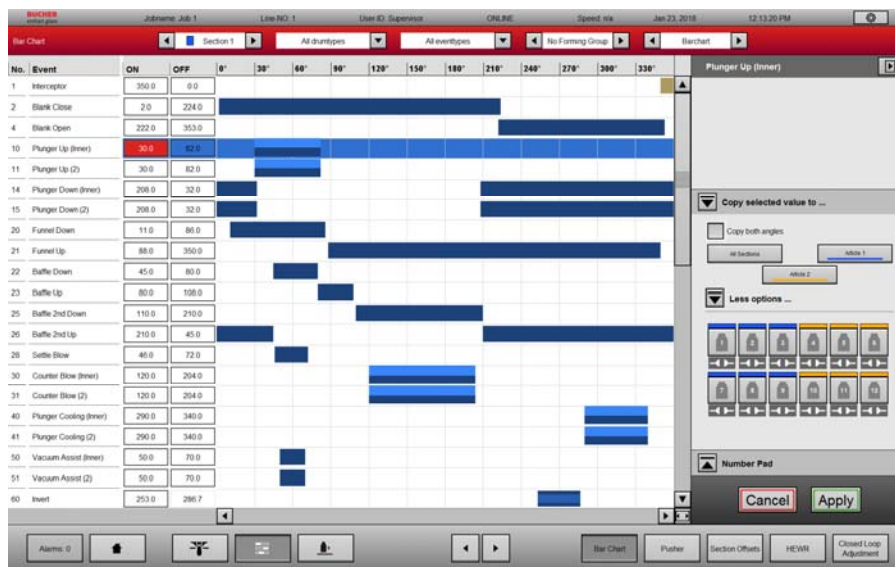

Multi Gob Application (MGA)

The newly developed feature, which allows a very powerful control of the gob forming for multi article production and is now fully integrated into UC2.

After a calibration procedure, you can directly enter the desired gob weight for every gob.

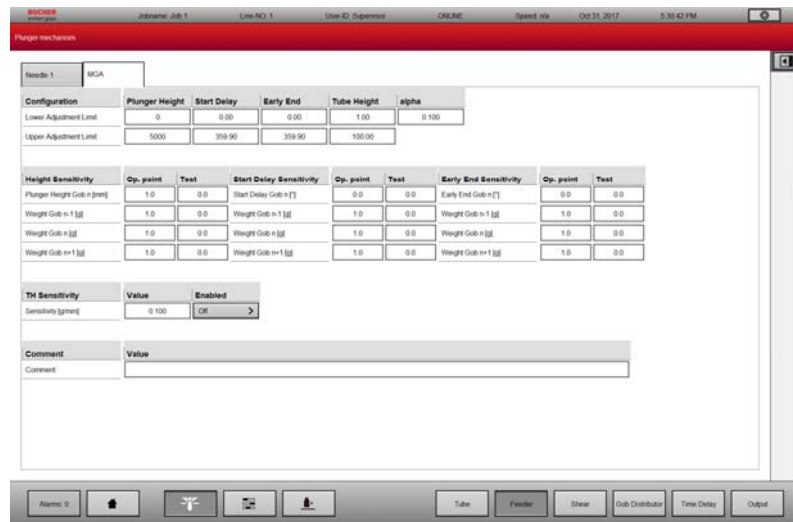

Tandem

With UC2 you operate a tandem machine with only **one** UC. It's of course possible to use more than one client (user interface) simultaneously.

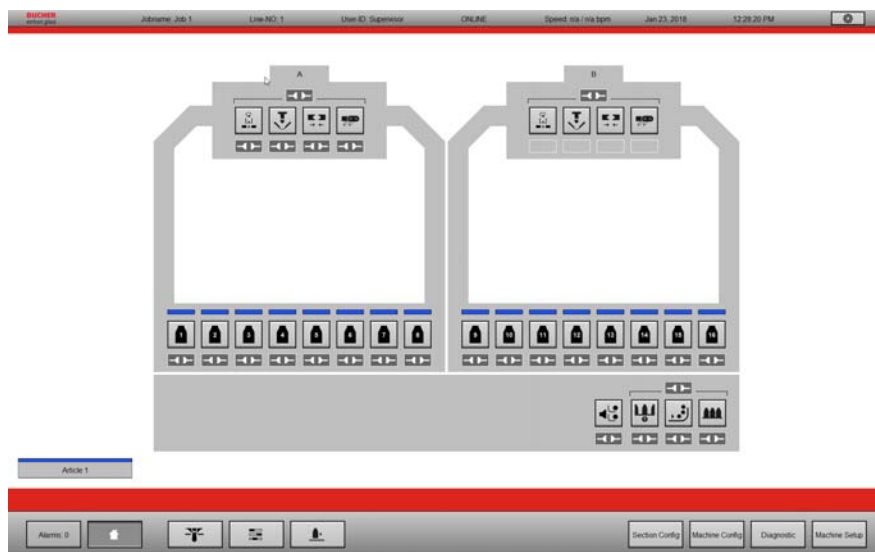

Multiple Clients

As already mentioned above it is possible to use more than one client (User Interface) at the same time. These clients work independently which means that you can operate on every client on different screens.

All clients send their individual changes to the UC2 server. The UC2 server is a central service, which handles all communication to the database, to the controllers and to all connected clients.

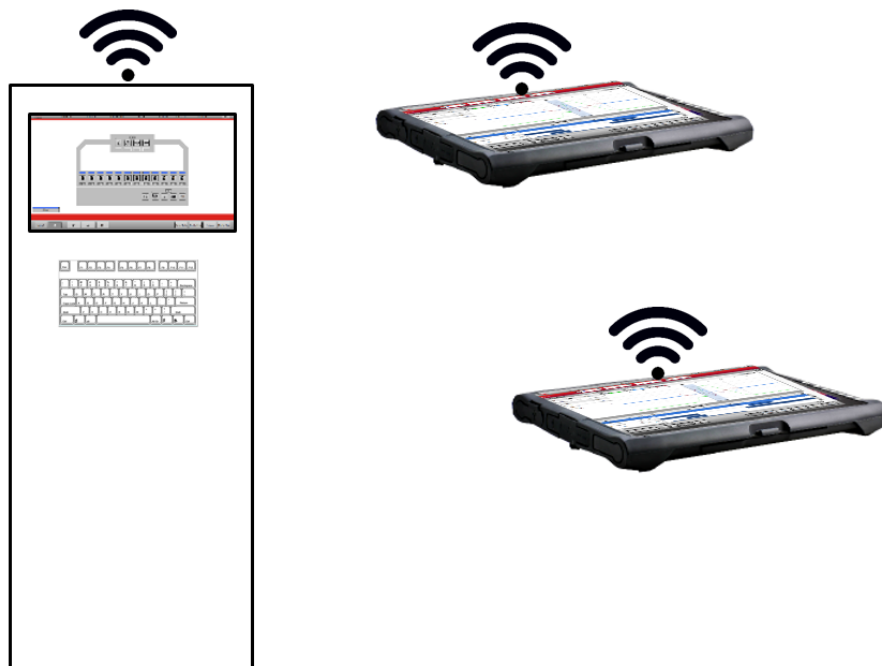

UC1 Upgrade to UC2

UC2 is not only available for FlexIS 3. It is easily possible to convert a FlexIS 1 system to FlexIS 2 by upgrading the UC1 system to UC2.



Parts to order for a UC2 upgrade:

601-11018	UC2 Computer
601-11071	Power Supply for UC2 Computer
601-10923	USB Cable
601-11115	DisplayPort Cable
601-11036	21.5" Touch Screen
601-12-10	WLAN Access Point Kit
601-10509	Ethernet Switch
601-20106	FlexPad
601-20107	Docking Station
601-11127	Adapter Frame for screen

Technical Specification

Size of cabinet

Width: 600 mm
Height: 2000 mm
Depth: 600 mm

Touch Screen

Screen Size: 21.5 inch
Screen Resolution: 1920x1080 pixel

Power Requirements

Voltage: 230 VAC
Power Consumption: 1 kVA

