

Technical News Bulletin

January 2018

Enhanced VertiFlow mechanism with removable vacuum duct

The enhanced VertiFlow through the bed mechanism is now the standard for IS and AIS machines for all their configurations (SG/DG/TG/QG).

This mechanism replaces the previous standard VertiFlow through the bed and is the default blow mold cooling mechanism for all the new pneumatic machines.

The VertiFlow through section mechanism (191-9700) remains available for applications where the cooling supply through the bed is not possible.

The latest design allows for a faster conversion (SG>DG>TG), for a quick replacement of the vacuum tubes for cleaning purposes and for higher mechanism efficiency.

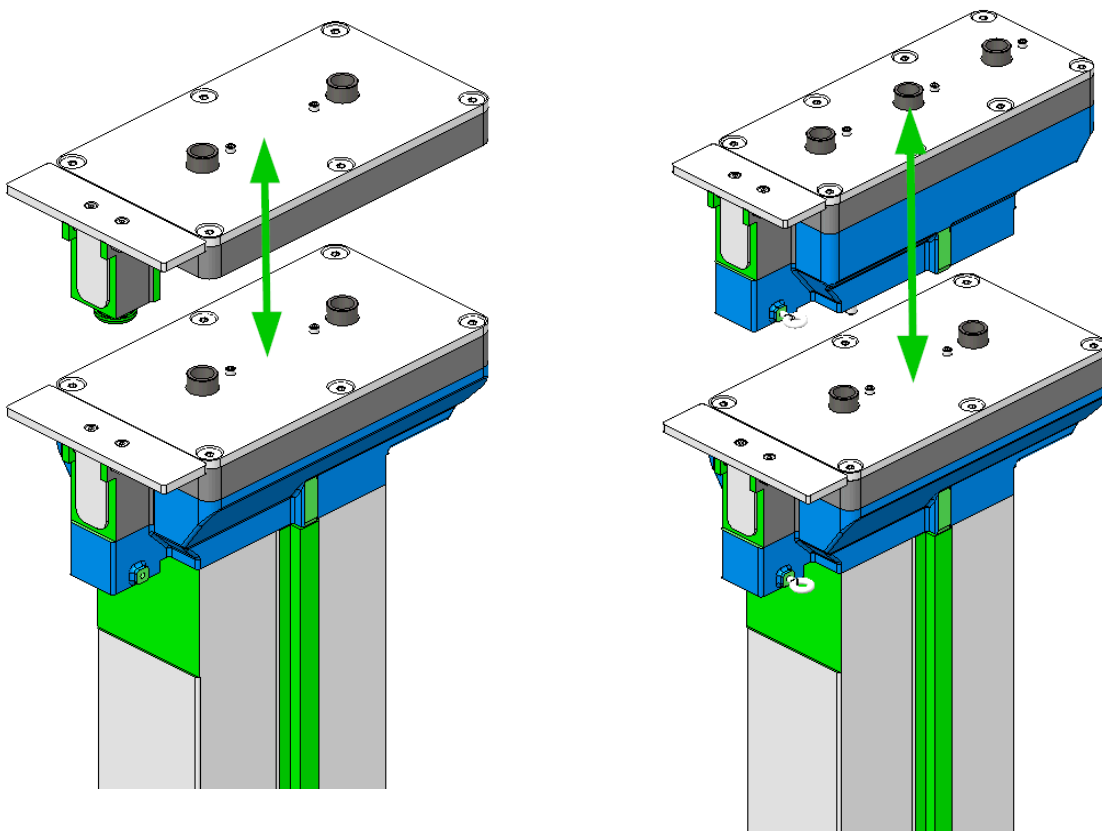

For converting the machine from SG to DG or TG the upper bracket has to be replaced. After the distributor plate removal, the screws which are fastening the upper bracket to the lower bracket are easily accessible for a fast conversion.

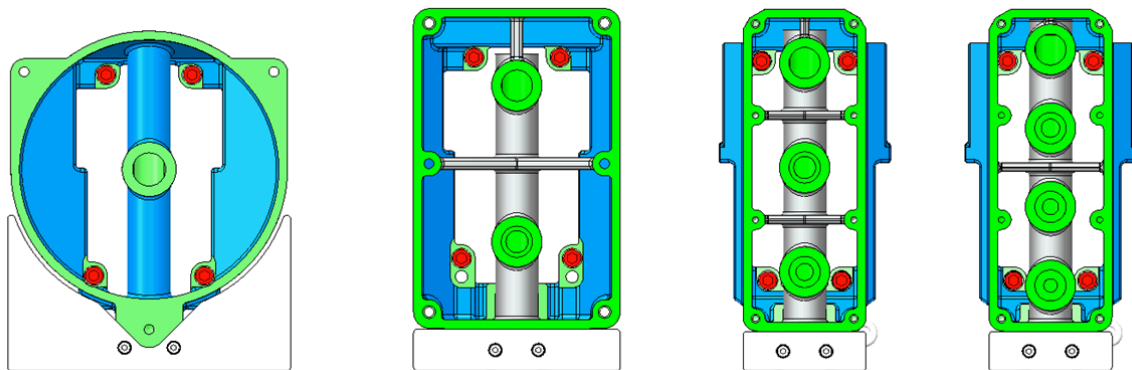

The vacuum tubes are now removable for cleaning purposes in DG, TG and QG configuration for an improved maintainability and higher mechanism efficiency. The same screws secure the distributor plate and the vacuum tube. Once the distributor plate is out, the vacuum manifold is free to be removed without the needs of tools.

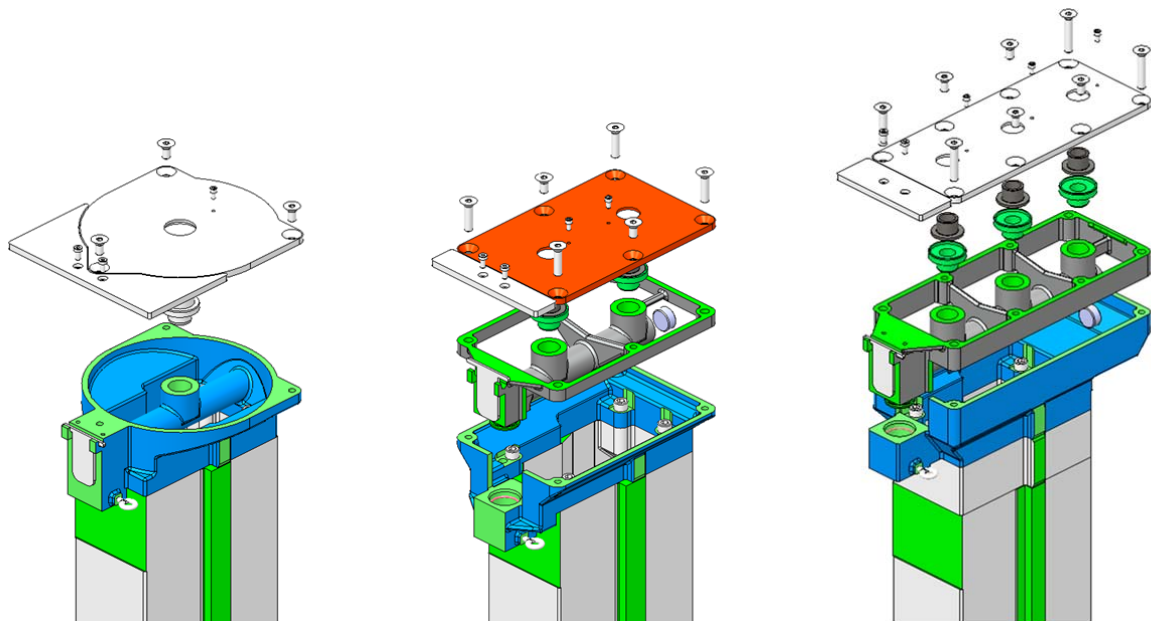

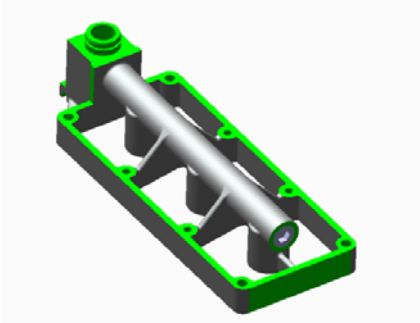

The straight vacuum tube design allows for an easy and efficient cleaning operation.

Vacuum tubes are integrated in a rigid frame with bracers for improved strength and handling.

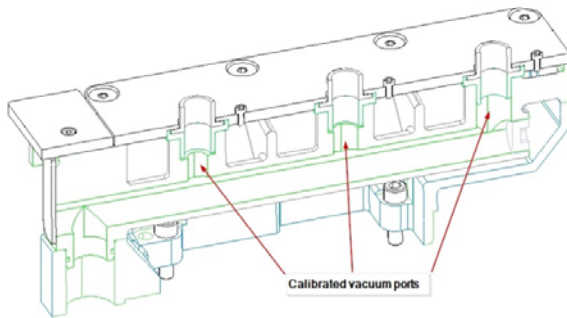

Vacuum flow for each cavity is equally balanced by a specific porting in the vacuum ducts.

Specification

The VertiFlow through the bed possible configurations are listed in drawing 210-2100-00.

IS and AIS T.T.B. VertiFlow mechanism correspondence			
Machine type		Old mechanism	New mechanism
4-1/4"	SG	200-432-1	210-2100-13
	DG	200-430-1	210-2100-14
	TG (3")	200-434-1	210-2100-15
5"	SG	200-425-1	210-2100-9
	DG	200-423-1	210-2100-10
	TG (85 mm)	200-370-2	210-2100-11
	QG (64 mm)	N/A	210-2100-12
5-1/2"	SG	210-332-1	210-2100-7
	DG	210-330-1	210-2100-8
6-1/4"	SG	210-336-1	210-2100-1
	DG	210-334-1	210-2100-2
	TG	210-338-1	210-2100-3
6-1/4" (+65)	SG	N/A	210-2100-4
	DG	N/A	210-2100-5
	TG	N/A	210-2100-6
AIS	DG (6-1/4")	210-334-1	210-2100-2
	TG (4-1/4")	210-338-1	210-2100-3
AIS (+65)	DG	N/A	210-2100-5
	TG	N/A	210-2100-6

Installation requirements

- The standard VertiFlow mechanism 210-2100 can be installed in all the existing IS and AIS machines.
- The new mechanism allows for a full compatibility with the equipment previously in use. Existing distributor plates and bottom plate equipment in use on the old VertiFlow mechanism will fit on the new one.
- Height adjustment is the same as the previous mechanism.
- Cooling duct in the machine bed is the same as the previous mechanism.
- Mold design limits remain unchanged.

Features / Benefits

Features	Benefits
Removable vacuum tubes	Improved maintainability and higher mechanism efficiency
Smaller upper support bracket	Faster machine conversions
Balanced vacuum flow	Higher efficiency
Customer equipment compatibility	Zero transition costs