

Technical News Bulletin

April 2010

FlexPusher Improved Robustness

Introduction

Since the launch of the FlexPusher more than 1600 mechanisms have been successfully supplied. In some installations it has been reported that the upper belt has, occasionally, suffered premature failure. Investigations have proven that the operating temperatures were in some cases, very close or exceeded the temperature specification of the belt.

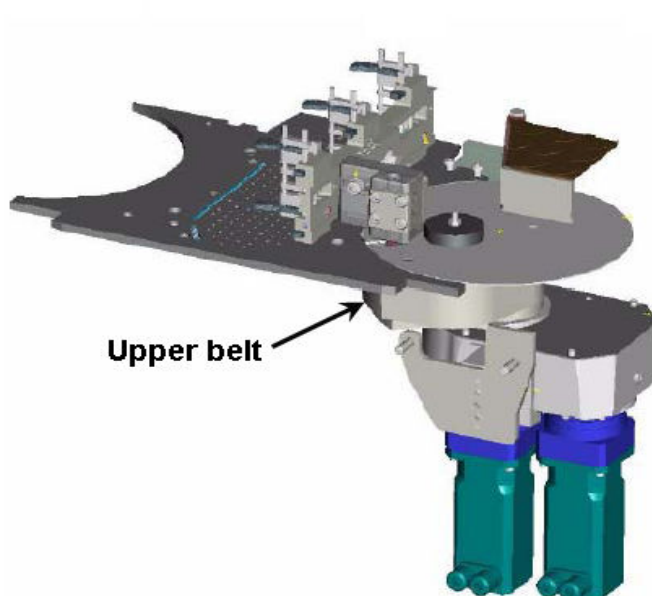
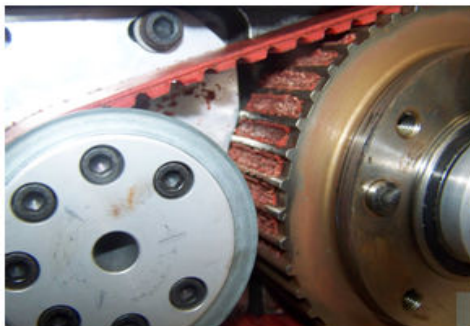

Improvement

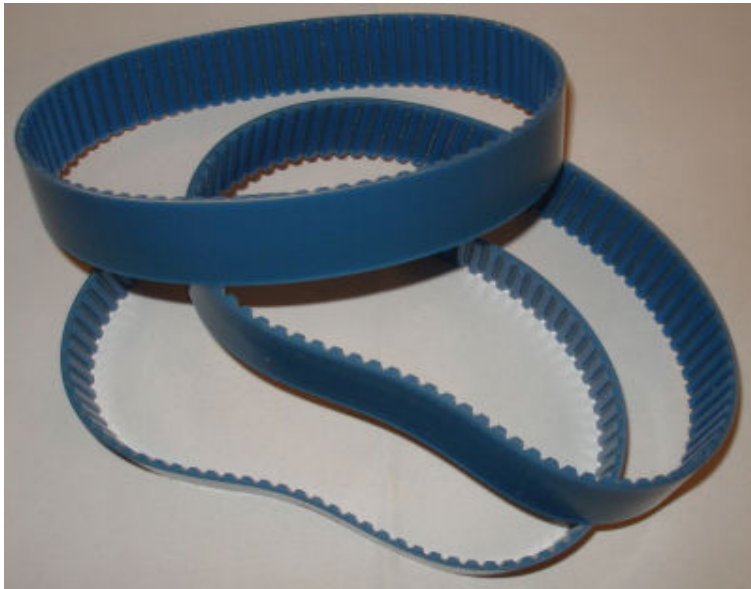

This issue has been addressed as follows:

A new High Temperature Belt 59-90491, has been designed and after testing in the field, introduced as standard.

In addition, in order to reduce the temperature around the housing cooling holes have been introduced.

This small modification, recommended for all installations is fully described on drawing number 904-60.

Conveyor girder beams delivered from last October have been provided with these cooling holes as standard.

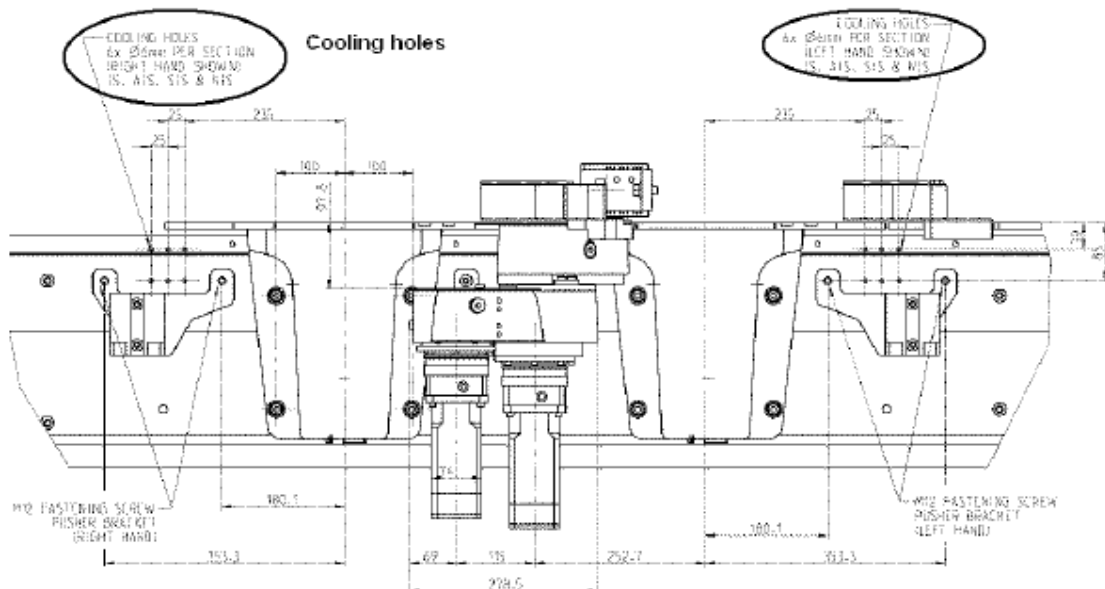

Field Upgrade

Emhart Glass will supply one high temperature upper belt 59-90491 for all pushers supplied. Shipping starts in June –July 2010.

How to exchange the belt

During a job change with Flexpusher mechanism mounted on conveyor, to exchange the belt follow this procedure:

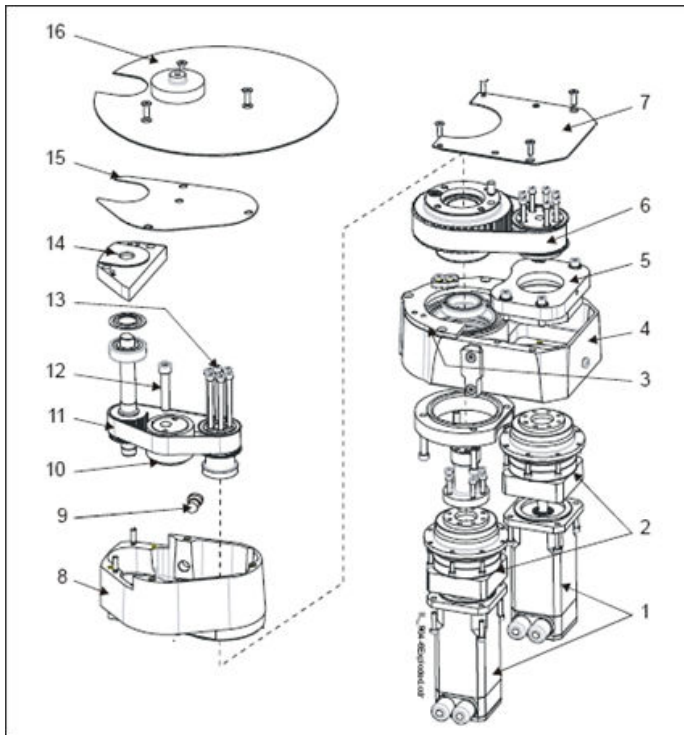

Figure 2-19: FlexPusher Upper and Lower Housings - Exploded View

1. Servo motors	9. Plug
2. Gearboxes	10. Tensioning pulley
3. End cover	11. Belt
4. Lower housing	12. Tensioning pulley screw
5. Tensioning plate	13. Drive pulley screws (7)
6. Lower belt	14. Upper housing cover
7. Lower housing cover	15. Heat insulation gasket
8. Upper housing	16. Top circular cover

- a. with the covers (index 16-15) removed, loosen the tensioning pulley (index 10)
- b. Remove the upper housing cover (index 14). Loosen the two screws holding the cover and press on them to pull the cover out.
- c. Remove the belt (index 11) and replace with HT 59-90491.
- d. Remove the plug (index 9) located on the side of the upper housing (index 8) and insert the tensioning tool 94-461-1.
- e. Move the tensioning pulley to align the two scribed lines on the tensioning tool and tighten the screw (index 12) in this position.
- f. Check for the alignment of the scribed lines. Readjust if necessary.
- g. Remove the tensioning tool and insert the plug.
- h. Follow steps a & b in reverse, to reassembly the mechanism.