

Technical News Bulletin

March 2009

Improved Take Out Arms



1. Introduction

The Servo Electric Take Out is gradually becoming the standard Take Out for all our machines. With increasing production speeds the load on the mechanical part is increasing. After the improvements on the gearbox (TNB 151), the Take Out Arms have been also improved to meet the demands in terms of precision and reliability.

2. Improvements

The latest generation of Take Out Arms have many improvements to increase performance and lifetime. The bearings of the arm are now pressed into steel bushings for a more rigid guiding. This design makes the bearing seats less sensitive for heat expansions caused by varying production conditions. Pre-lubrication of the bearings with Klübersynth BH 72-422, a high temperature grease, also increases the service life. The outer bearing which has the highest heat load has been changed from a ball bearing to a spherical roller bearing to further increase the lifetime of the mechanism.

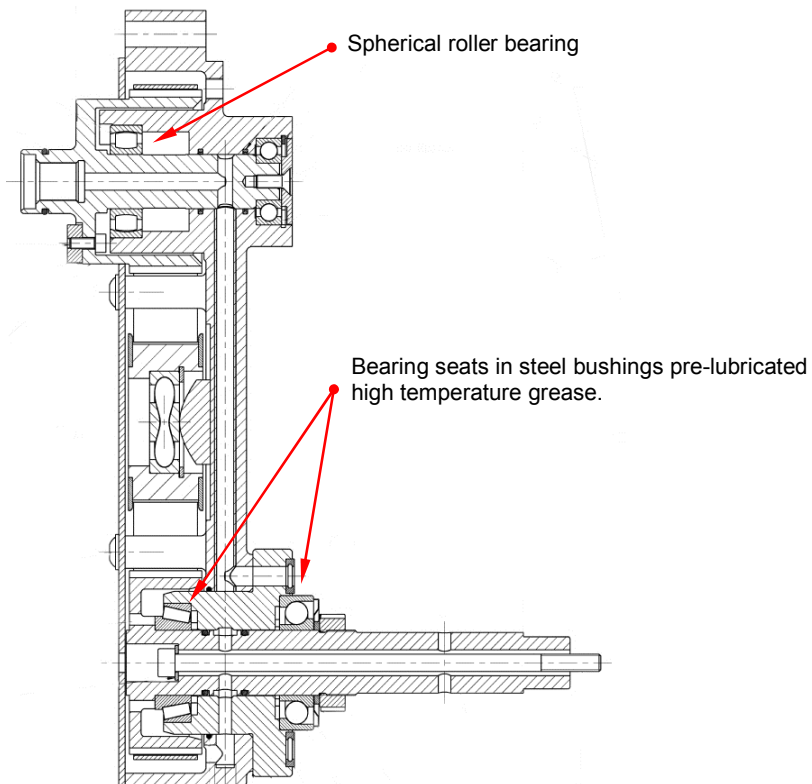

Example of the 210-439-02 for 51/2 DG and AIS

3. Compatibility

The new generation of take out arms will fit with the Emhart Glass take out gear boxes 210-480. All new arms are supplied with the deep keys for the latest version of take out gear boxes (see TNB 151). However the keys can be exchanged to fit the previous version.

	Key 1	Key 2
Deep Grove	400-51267	400-51266
Standard Grove	210-12315	210-12203

Machine Configuration	DG 4 1/4 - TG 3"	DG 5" - TG 85mm	DG 5 1/2 - AIS	NIS
Old Generation	200-2031-1	200-2032-1	210-439-1	400-5084-1
Latest Generation	200-2031-2	200-2032-2	210-439-2	400-5084-2

4. Availability

The new generation Take Out arms are available from now on.