

## Technical News Bulletin

June 1999

### ON/OFF CONTROL MECHANISM

Now for all Type IS Machines

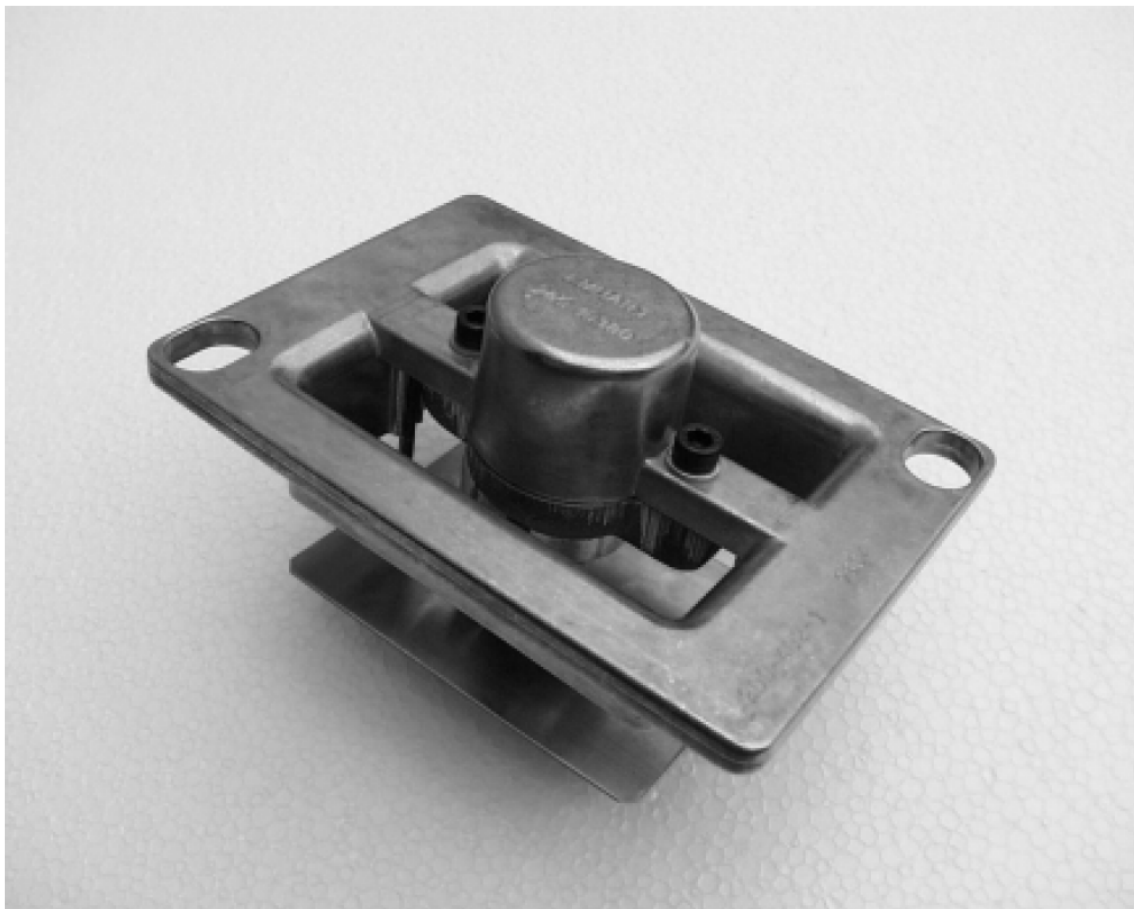

ON/OFF Control Mechanism

## Introduction

Enhanced performance through genuine, reliable simple design (Patent pending). This is the characteristic of the new cooling air ON/OFF Control Mechanisms for the cooling stacks of the Type IS machines of all center distance configurations.

## Description

The ON/OFF Control Mechanism consists of only 5 main parts (Fig 1): the body, a precision die casting, a cylinder, a sealing plate attached directly to the piston & rod and a strap.

The piston is spring operated to maintain the sealing plate in the closed position and pneumatically operated for cooling air ON. End of stroke cushioning of piston down is by means of an O-ring. In the absence of a piston ring this O-ring serves also as a seal to prevent pressure loss in the cylinder. The sealing plate is designed as a flat spring which acts against the concave lower surface of the body frame. This cushions the impact and provides at the same time a good seal.

The strap guides the plate to prevent it from twisting and interfering with the plunger hoses.

The air flow rate measured with the new ON/OFF Control mechanism surpasses that of the previous mechanisms by up to 30%, depending on the location and obstructions within the section frame.

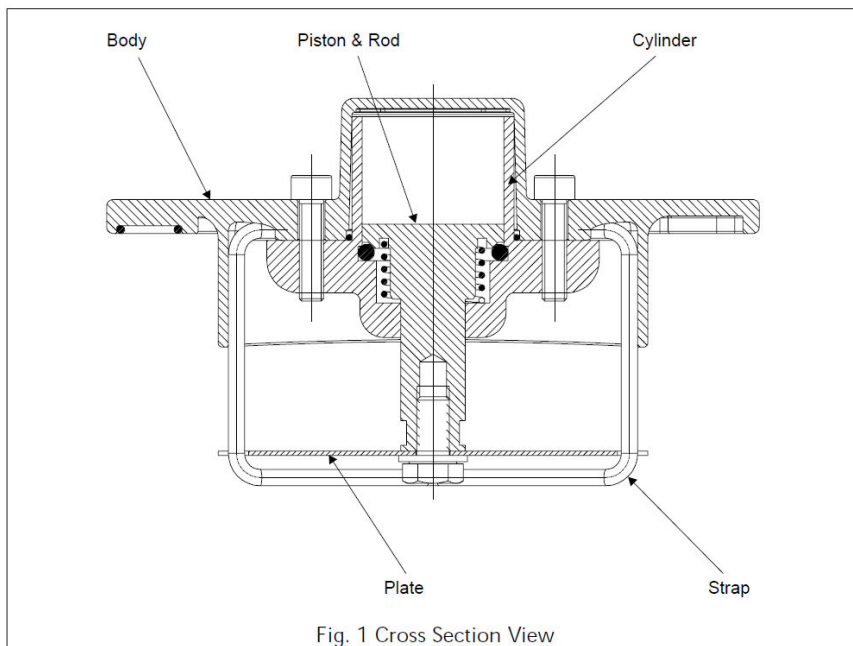

## Installation

The new ON/OFF Control Mechanisms are a direct replacement for the previous mechanisms and can thus be installed without the need of any alteration to the section frame. On sections having previously "normally open" mechanisms installed, the corresponding "NO" cartridge valve in the electro-pneumatic valve block must be replaced by an "NC" cartridge valve.

## Operation

The new ON/OFF Control Mechanisms are designed to meet the following specification:

Cooling air pressure, maximum:	1'500 mm WC
Operating air pressure:	2.1 bar
Operating air quality:	Class 4 ISO 8573
Lubrication:	Not required

## Specification

The new ON/OFF Control Mechanisms are designed to be operated on blank and blow side cooling stacks as specified below:

Machine Type	Position	ON/OFF Control Mechanism	
		New Part No.	Superseded Part No.*
E & EF 4-1/4	Blank & Blow Side	200-402-1	191-9012 & 200-294
E & EF 5"	Blank & Blow Side	200-402-1	191-9012 & 200-294
F & EF 5-1/2	Blank Side LH	200-477-1	23-1414 & 23-1734
	Blank Side RH	200-477-2	23-1414 & 23-1734
	Blow Side LH	200-477-3	23-1414 & 23-1734
	Blow Side RH	200-477-4	23-1414 & 23-1734
F & EF 6-1/4	Blank Side LH	200-477-5	23-1734 & 23-3339
	Blank Side RH	200-477-6	23-1734 & 23-3339
	Blow Side LH	200-477-3	23-1414 & 23-1734
	Blow Side RH	200-477-4	23-1414 & 23-1734

\* Includes all assembly groups of listed part numbers

The ON/OFF Control Mechanism 200-402-1 has been available since June 1998 while the full range of 200-477 mechanisms will be available by June 1999. The previous type mechanisms have been discontinued and are no longer supplied as complete units. The type 200-294 and 23-1734 mechanisms are supported with spare parts until the end of the year 2000, respectively 2001. Spare parts for all other superseded mechanisms are no longer available.

## **Features and Benefits**

- Simple, maintenance free design
- Rated for cooling air pressures up to 1'500 mm WC
- Directly interchangeable with previous products
- Increased air flow