

## Technical News Bulletin

27-Jun-07

### New AIS Blank Supporting Bracket with InVertiFlow and VertiFlow Cooling

The Blank supporting bracket 210-294 as introduced 1995 offered a reliable way to form containers using parallel mold motion. The new AIS Blank supporting bracket 210-470 adds now additional versatility of cooling options as it allows to operate with both the known **VertiFlow** and the **new InVertiFlow** cooling configuration. The VertiFlow system uses plenum chambers on top of the blank molds, passing cooling air through vertical holes to the bottom of the blank molds. With the new InVertiFlow blank mold cooling system the airflow has been “inverted”, passing the air from plenum chambers at the bottom – or lower end – to the top of the blank molds. This new cooling system offers additional benefits:

- Higher cooling efficiency → Speed increase potential
- Individual cooling of mold halves → Optimized cooling conditions
- Heat carried away → Reduced heat impact on mechanism
- Easier mold change → Reduced down time

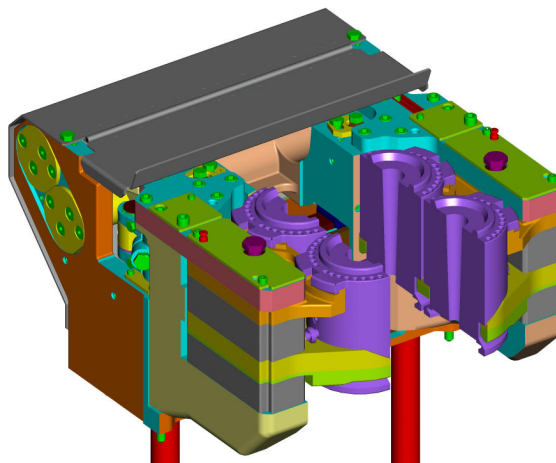

Figure 1 – Blank Supporting bracket with DG InVertiFlow configuration

The well proven mechanical concept of the parallel opening and closing was also further improved, offering additional benefits:

- Improved stiffness, mold guiding and closing → Reduced seams
- Improved lubrication → Increased mechanism life

## Design principle

The Blank Mold Supporting bracket consists of a bracket with two arms. The opening and closing action of the mold holders is provided by the mold open and close mechanism located in the base of the section. The force of this assembly is transmitted to the mold holder, left and right hand arms, by means of spline shafts, levers and links. The mold holder arms travel horizontally on slider bars and a flat guidance to provide a parallel mold open/close motion. The mold holder arms are integrated parts of the mechanism. The arms slide on individual guide bars by means of two bearings. The annular space between the bearings acts as an oil reservoir.

Lubrication oil supply to this reservoir is made via portings in the guide bars and bracket. The arms are supported by sliders running on a flat slide bar. The sliders are connected to adjustment screws which also serve as link pins. The fine thread of the adjustment screw allows precise leveling of the arms.

The support bracket has in its base four holes which are connected via grooves to the top plate opening for the section, allowing the cooling air from the section frame to flood the slider bar system of the mechanism. The cooling wind air flows from the section frame to the blank mold supporting mechanism into the four channels of each arm, and is controlled by eight individual on/off valves (four per arm) mounted inside the bracket. The actuation of the valves depends on the individual cooling configuration. The air piping to operate the on/off valves comes from the Electro-Pneumatic Valve Block (EPVB) to the terminal block which is mounted on the top plate of the section frame.

The mold holder and cooling assembly for VertiFlow is in principle unchanged to the old blank bracket. The configurations are documented in the mold design handbooks for AIS 4 ¼``TG and AIS 6 ¼``DG. The mold holder and cooling assembly for the InVertiFlow system is shown in Figure 2.

Individual spacers mounted between mold holder insert and plenum chamber vary the position of the plenum chamber. The 6 mm height increment of these spacers gives full flexibility to match the desired plenum position and therefore the desired air inlet position. The whole assembly is secured by mounting tubes with screws.

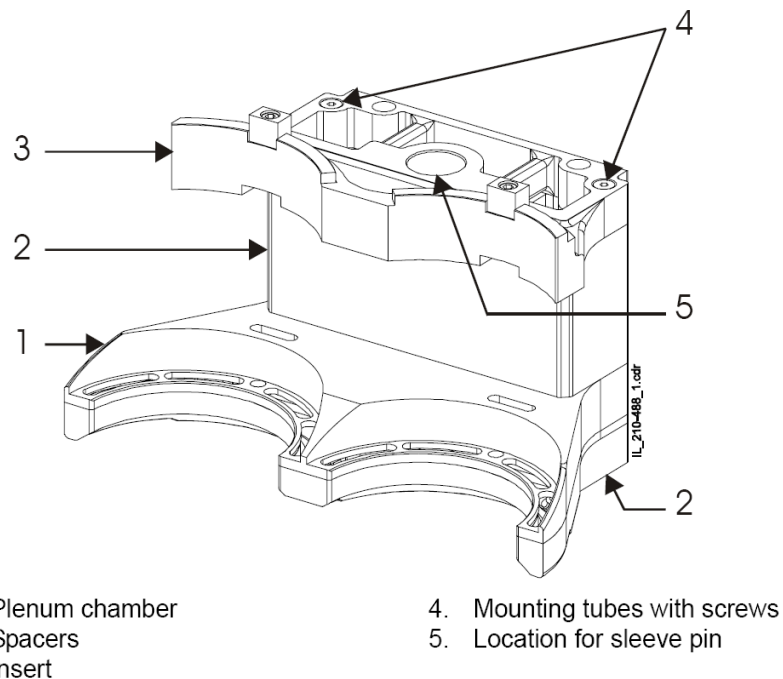

**Figure 2 - InVertiFlow Mold Holder and cooling assembly in DG configuration**

## Specification

The new bracket allows to run VertiFlow and InVertiFlow cooling configurations. New machines are configured for InVertiFlow cooling as a standard unless otherwise specified.

In order to run the VertiFlow configuration, the bracket itself (210-470) together with accessories according to 210-473 have to be specified. Existing plenum chambers and mold holder inserts from the old bracket can be used.

To use the InVertiFlow configuration the bracket 210-470 and accessories according to 210-488 are necessary. The principal configuration of the InVertiFlow Mold Holder and cooling assembly is shown in Figure 3 for DG and in Figure 4 for TG configuration.

Additionally it is possible to feed air from the top to cool the baffle via a nozzle. For set-up of this non standard configuration please refer to the mold design handbooks for AIS 4 ¼`TG and AIS 6 ¼`DG.

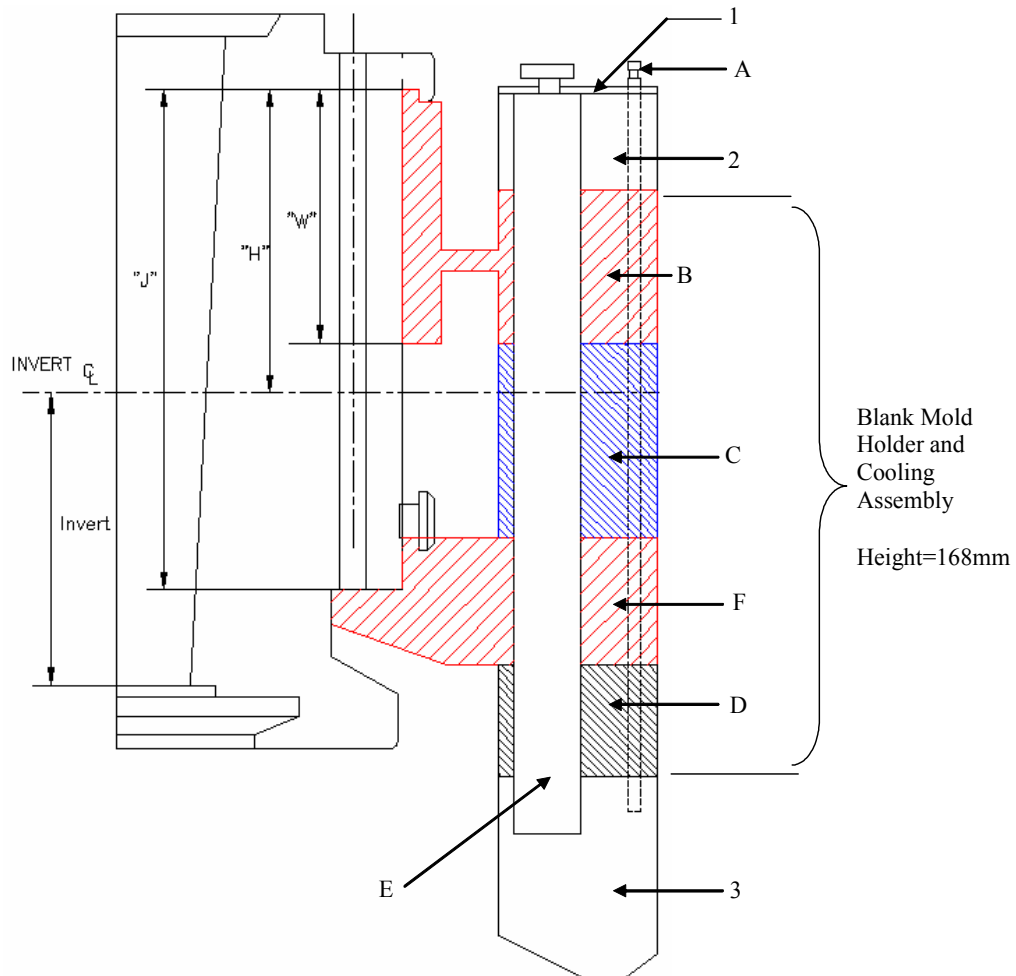

Parts of Supporting mechanism

- 1 Cover Plate 210-12533
- 2 Top Plate 210-12523
- 3 Arm see 210-470

Accessories on 210-488

- A Limit Pin
- B Mold Holder Insert
- C Upper Spacer
- D Lower Spacer
- E Sleeve Pin
- F Plenum Chamber

**Figure 3 - InVertiFlow Mold Holder and cooling assembly selection in DG configuration**

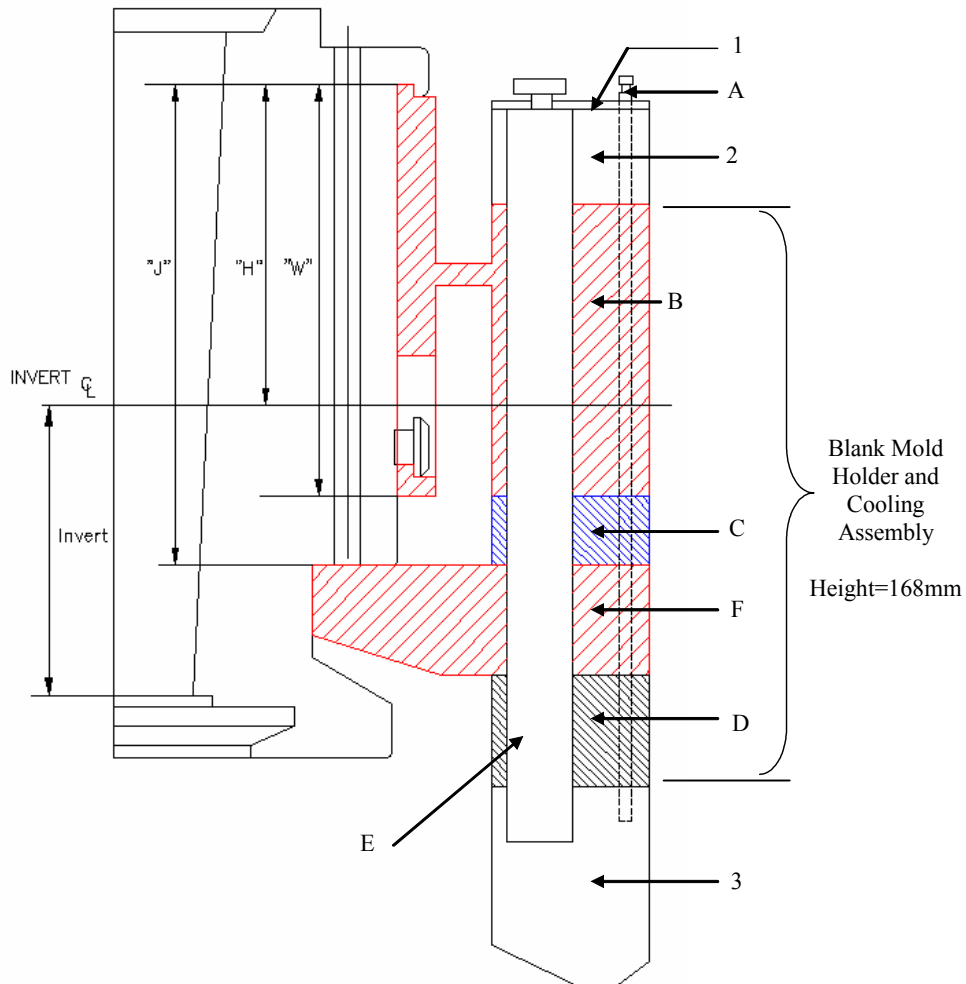

Parts of Supporting mechanism

- 1 Cover Plate 210-12533
- 2 Top Plate 210-12523
- 3 Arm see 210-470

Accessories on 210-488

- A Limit Pin
- B Mold Holder Insert
- C Upper Spacer
- D Lower Spacer
- E Sleeve Pin
- F Plenum Chamber

**Figure 4 - InVertiFlow Mold Holder and cooling assembly selection in TG configuration**

Important remark concerning individually cavity control of the cooling

Using the InVertiFlow configuration the bracket offers the possibility to time the cooling of every cavity separately as an **option**. However this is only possible on new machines if as a minimum FPS for plunger up **and** SETO are specified along with the standard 26 line valve block. **For retrofits no individual cavity control is available.**

## **Installation**

In contrast to the old bracket two more lubrication lines are needed. Depending on the cooling configuration more lines to operate the on/off might be needed. Customers that have the aligning fixtures for the old bracket 210-294 have to order aligning fixtures according to 94-638.

For replacing the old bracket with the new one (**no** individual cavity control possible !) two M6 bores have to be drilled in the section frame according to the drilling fixture 94-714. Section frames supplied after June 2007 have this modification included already. The old bracket has to be taken off and replaced by the new one. Two additional lubrication lines have to be connected to the bracket and the on/off piping has to be reworked. If necessary NO cartridge valves have to be replaced with NC valves in the EPVB for the on/off control valves. For details on replacing the bracket please refer to Instruction and Installation manual TW2103.

## Ware Range and Mold Design

The InVertiFlow cooling system is designed to accept, with some minor modifications, existing blank molds used with the VertiFlow cooling system. Blank molds used with conventional stack cooling may be used providing the cooling holes will not interfere with the cooling fins.

For the blank mold design and necessary modifications of existing VertiFlow molds refer to the AIS mold design data handbooks for AIS 4 ¼`TG and AIS 6 ¼`DG .

The ware range given in Figures 5 and 6 is based on the use of standard mold equipment as specified in the mold design data handbooks. For more details concerning the ware range limits of the individual mounting assemblies please refer also to the mold design data handbooks.

Process	Q.C. Cartridge / Positioner	Neck Ring			Invert Height (mm)		Min Blank Glass Line	Min Height under Finish
		Max. Finish Dia.	Height (mm)	Dovetail Dia. (mm)	Mini	Maxi		
BB	62-3036-8	33	48	89	35	135	119	140
	62-186-3	33	48	89	35	133	119	140
	62-3036-8	48	57	101.5	26	126	110	130
	62-186-3	48	57	101.5	26	124	110	130
NNPB	Plunger Mechanism 62-11019 on DG Base Plate							
	62-404-9	38	67	101.5	30	84	70	90
	Plunger Mechanism 62-11020 on TG Base Plate							
	62-404-8	38	67	101.5	30	104	70	90
PB	Plunger Mechanism 62-11019 on DG Base Plate							
	62-402-12	70	67	114.5	30	89	70	90
	62-402-11	83	73	127	30	75	70	90
	62-402-10	90	73	133.5	36	75	76	90
	62-475-2	105	73	143	39	51	79	90
	Plunger Mechanism 62-11020 on TG Base Plate							
	62-404-3	70	67	114.5	30	110	70	90
	62-402-2	83	73	127	30	75	70	90
	62-402-1	90	73	133.5	36	75	76	90
62-402-6	105	73	143	39	67	79	90	

**Fig 5: Ware range for 6 ¼`DG in InVertiFlow configuration**

Process	Q.C. Cartridge / Positioner	Neck Ring			Invert Height (mm)		Min Blank Glass Line	Min Height under Finish
		Max. Finish Dia.	Height (mm)	Dovetail Dia. (mm)	Mini	Maxi		
BB	62-3036-7	48	48	89	40	102	122	135
	62-170-11	48	48	89	40	93	122	135
NNPB	62-404-10	38	67	101.5	30	83	76	90
PB	62-404-6	60	67	101.5	30	83	76	90
	62-404-6	70	67	114.5	36	83	82	95

**Fig 6: Ware range for 4 ¼" TG in InVertiFlow configuration**

For the VertiFlow configuration there are some minor restrictions compared to the old bracket in the minimum blank glass line for the smallest H dimensions only (see Figure 7). For more details please see the Mold Design Handbooks.

Machine type	Restriction at H-Dimension of	Minimum blank glass line increased compared to 210-294 by
6 ¼" DG	28.6 mm	BB → 35mm PB → 45mm
4 ¼" TG	41.3 mm	BB → 25mm PB → 20mm

**Fig. 7: Restrictions of VertiFlow operation compared to old bracket**



## Characteristics

Compatibility with machine	AIS 4 ¼`TG AIS 6 ¼`DG
Opening travel per side	Nominal 82.5 mm 78.0 mm
Cooling wind pressure	1600mmWG max.
Operating air* for on/off	2.1 bar
Air consumption for 8 on/off valves	350cm <sup>3</sup> /cycle
Central lubrication	
Frequency	3/h minimum
Amount of oil	8.4cm <sup>3</sup> /h minimum
Type of oil	Type "A" synthetic

\* Refer to Emhart Glass Machine Instruction manual for quality of air

**Fig. 8: Characteristics of blank support bracket**

## References

Mechanism	Drawing 210-470
InVertiFlow and VertiFlow accessories	Drawing 210-490
Instruction and installation manual	TW 2103
Mold Design Handbook AIS 4 ¼`TG	TW 2061
Mold Design Handbook AIS 6 ¼`DG	TW 1988

## Features and Benefits

### General

- Unmatched versatility of cooling operation with offering improved and predictable InVertiFlow operation
- Improved mechanics

### InVertiFlow cooling

- Predictable cooling → More consistent container quality
- Reduced cooling time → Potential for higher production speed
- Easier mold change → Reduced down time
- Swabbing fumes carried away → Provides better working environment
- No heat load on section → Increased mechanism life
- Conversion of VertiFlow Molds → Use of existing mold stock
- One mold holder arm for → Reduced inventory
- wide ware range

### Improved Mechanics of Blank supporting bracket 210-470

- Improved stiffness → Reduced seams
- Improved mold guiding and closing → Reduced seams
- Improved lubrication → Increased mechanism life